



OSIPP Discussion Paper: DP-2023-E-002-Rev

Higher-Order Misspecification and Equilibrium Stability

September 4, 2023

Takeshi Murooka*

Osaka School of International Public Policy (OSIPP), Osaka University

Yuichi Yamamoto†

Institute of Economic Research, Hitotsubashi University

Abstract: This paper considers a Bayesian learning problem where strategic players jointly learn an unknown economic state, and show that one's higher-order misspecification (i.e., one's misspecification about the opponent's misspecification) can have a significant impact on the equilibrium outcome. We consider a simple environmental problem where players' production, as well as an unknown state, affects the quality of the environment. Crucially, we assume that one of the players is unrealistically optimistic about the quality of the environment. When this optimism is common knowledge, the equilibrium outcome is continuous in the amount of optimism, and hence small optimism leads to approximately correct learning of the state. In contrast, when the optimism is not common knowledge and each player is unaware of the opponent having a different view about the world, the equilibrium outcome is discontinuous, and even vanishingly small optimism leads to completely incorrect learning. We then analyze a general Bayesian learning model and discuss when such discontinuity arises.

JEL Codes: C73, D83, D90, D91

Keywords: model misspecification, learning, unawareness, convergence, stability, inferential naivety, overconfidence

* Email: murooka@osipp.osaka-u.ac.jp

† Email: yyamamoto@ier.hit-u.ac.jp

Higher-Order Misspecification and Equilibrium Stability*

Takeshi Murooka

Yuichi Yamamoto

Osaka University

Hitotsubashi University

September 4, 2023

Abstract

This paper considers a Bayesian learning problem where strategic players jointly learn an unknown economic state θ , and show that one's higher-order misspecification (i.e., one's misspecification about the opponent's misspecification) can have a significant impact on the equilibrium outcome. We consider a simple environmental problem where players' production, as well as an unknown state θ , affects the quality of the environment. Crucially, we assume that one of the players is unrealistically optimistic about the quality of the environment. When this optimism is common knowledge, the equilibrium outcome is continuous in the amount of optimism, and hence small optimism leads to approximately correct learning of the state θ . In contrast, when the optimism is not common knowledge and each player is unaware of the opponent having a different view about the world, the equilibrium outcome is discontinuous, and even vanishingly small optimism leads to completely incorrect learning. We then analyze a general Bayesian learning model and discuss when such discontinuity arises.

JEL CODE: C73, D83, D90, D91

Keywords: model misspecification, learning, unawareness, convergence, stability, inferential naivety, overconfidence

*We thank Matthias Fahn, Drew Fudenberg, Kevin He, Paul Heidhues, Botond Kőszegi, Shintaro Miura, Yoko Okuyama, Klaus Schmidt, and seminar and conference audiences for helpful comments. Murooka acknowledges financial support from JSPS KAKENHI (JP16K21740, JP18H03640, JP19K01568, JP20K13451, JP22K13365). Yamamoto acknowledges financial support from JSPS KAKENHI (JP20H00070, JP20H01475).

1 Introduction

Economic agents often take actions based on a misspecified view about the world: A worker may be overconfident about his own capability, a firm may incorrectly assume that the demand function is linear in prices (in reality, the demand is non-linear), an investor may incorrectly believe that the economy is driven by fewer variables, and so on.¹ Recent literature on model misspecification studies how such a bias influences the agents' behavior and payoffs, assuming either a single-agent setup or a multi-agent setup in which the agents' misspecifications are common knowledge (e.g., Esponda and Pouzo, 2016; Heidhues, Kőszegi, and Strack, 2018; Ba and Gindin, 2023). However, this common knowledge assumption leaves out many potential applications, as it does not allow players' *higher-order misspecification*. For example, when a worker is overconfident about his own capability, his colleague may not be aware of it; in this case, this colleague has a misspecified view about the opponent's view about the world.

This paper shows that such higher-order misspecification has a significant impact on players' play. In particular, we find that even a negligible amount of misspecification can drastically change the equilibrium outcome. To illustrate this, we consider a simple model of an environmental problem with two players. There are infinitely many periods, and the players' production, as well as an unknown state θ , influences the quality of the environment each period. We assume that one of the players (say, player 2) is misspecified and is unrealistically optimistic about the quality of the environment. Players are myopic, and actions are unobservable.

In Section 2, we consider a benchmark case in which the players do not have higher-order misspecification, and each player correctly understands the opponent's view about the world. That is, player 1 knows that she is more pessimistic than player 2, while player 2 knows that she is more optimistic than player 1. (Also, these beliefs are common knowledge.) As we show in our companion paper (Murooka and Yamamoto, 2023), in this case, the players' beliefs about the unknown state θ eventually converge to a steady state almost surely, regardless of the initial common prior. This steady-state outcome is continuous with respect to the level of player 2's bias

¹ As experimental and empirical evidence, people exhibit overconfidence in strategic entries (Camerer and Lovo, 1999), corporate investments (Malmendier and Tate, 2005), and merger decisions (Malmendier and Tate, 2008). See Daniel and Hirshleifer (2015), Malmendier and Tate (2015), and Grubb (2015) for reviews of the literature.

(i.e., optimism). So when player 2's bias is small, its impact on the long-run outcome is small, i.e., after a long time, the players have approximately correct beliefs about θ .

Then Section 3 considers the model with higher-order misspecification, where the players are unaware of the opponent having a different view about the world. Specifically, player 2 is optimistic about the environment, and on top of that, she naively thinks that the opponent shares the same view with her. (In reality, player 1 isn't optimistic.) Similarly, player 1 has the unbiased view about the environment, and naively thinks that player 2 also has the unbiased view.

As in the benchmark case, when player 2's optimism is small, there is a steady state in which the players approximately learn the true state θ^* . However, it turns out that this steady state is unstable, and the players' beliefs converge there with *zero* probability; indeed, the players' beliefs tend to be polarized over time and converge to a boundary point almost surely. This result shows that the players' higher-order misspecification has a significant impact on the long-run equilibrium outcome. With small optimism of player 2, the players approximately learn the true state if the optimism is common knowledge, while their beliefs converge to boundary points if the players are unaware of the opponent having a different view about the world.

Our result also shows discontinuity of the equilibrium outcome with respect to the information structure. Indeed, the players' long-run beliefs are concentrated on the true state in the case of no misspecification, but these beliefs jump to boundary points once player 2 has (even vanishingly small) optimism. One may think that this discontinuity contradicts with various continuity results in the literature on incomplete information; e.g., Chen, Di Tillio, Faingold, and Xiong (2017) show that a small change in information structure can have only a small impact on equilibrium in any normal-form game. We will explain how to reconcile this in Section 3.3.

In our model, instability of the steady state is closely related to the inferential naivety arising from the players' higher-order misspecification. Since player 1 is unaware of player 2's optimism, she believes that player 2 will maximize payoffs and update the belief given the unbiased view about the environment (but in reality, player 2 does so given the optimistic view about the world). It turns out that this inferential naivety (about the opponent's action and belief) is *reinforced* through learning in our model; a small gap between one's belief about the opponent's belief (about the

state) and the opponent's actual belief can become arbitrarily large after a long time. As we will explain in Section 3.3, this is the source of the instability of the steady state.

Recent work by Frick, Iijima, and Ishii (2020) shows that a small misspecification can lead to a complete breakdown of correct learning, in the context of social learning. In their model, agents observe the opponents' actions every period and learn a payoff-relevant unknown state from it. The agents are misspecified in that they have incorrect views about how the opponents interpret information (and hence they have incorrect views about the opponents' behavior). They show that a steady state is discontinuous in the amount of misspecification, and in particular, even with a vanishingly small amount of misspecification, in the unique steady state, the agents have a point-mass belief on a state which is far away from the true state.

Frick, Iijima, and Ishii (2020) also argue that their result relies on the assumption that the agents have only a limited amount of information about the state, in that the agents observe a noisy signal about the state only once. (So the agents learn mostly from the opponents' actions, and in this sense it is a model of social learning.) Indeed, they show that if the agents observe signals in every period of the infinite-horizon model, then the result is overturned and steady states are continuous in the amount of misspecification. So one may naturally expect that a small misspecification can destroy correct learning in social learning models, but not in models where agents receive feedbacks (i.e., signals) repeatedly. Note that repeated feedbacks are common in many economic applications; e.g., if agents observe their own payoffs every period, then it is a model of repeated feedbacks, as payoffs are informative about the state in general.²

Our result shows that such a conjecture is not true, and a small misspecification can still have a huge impact on the learning outcome even in a model of repeated feedbacks. In our model, when the agents become slightly misspecified, the probability of the belief converging to the steady state suddenly drops from one to zero. So even though a small misspecification has only a negligible impact on the steady state, it leads to a complete breakdown of correct learning. This is a new mechanism which causes discontinuity of the learning outcome, and in this sense our work complements Frick, Iijima, and Ishii (2020).

² Frick, Iijima, and Ishii (2020) assume that the agents do not observe payoffs.

In Section 3.4, we extend this non-convergence result to a general setup, and study when a small amount of misspecification leads to a complete breakdown of correct learning. We find that learning tends to be fragile when the state θ and one's belief about the state θ have opposite impacts on the outcome. As we will explain, this condition can be satisfied in a wide range of economic applications, such as team production and Cournot competition.

To prove the fragility of correct learning, we extend the non-convergence result of Pemantle (1990), which shows that if a steady state of a stochastic process is unstable in some sense, then the process converges there with zero probability. His theorem does not apply to our setup directly, for three reasons. First, we assume that players observe *public* signals and update their beliefs, so the stochastic shocks on these beliefs are perfectly correlated. Assumption (iii) in Theorem 1 of Pemantle does not allow such a correlation. Second, we consider a Gaussian noise, which violates the bounded support assumption of Pemantle. Third, the drift term of our stochastic process involves a perturbation term, which is not considered by Pemantle.³ We show that these features do not cause a serious problem, and the result of Pemantle remains valid in our environment. We believe that this result can be useful for future works which consider a stochastic process similar to ours (in particular, problems in which stochastic shocks are Gaussian or shocks on multiple variables are perfectly correlated).

2 First-Order Misspecification

2.1 Setup

As a benchmark, we first consider the case in which higher-order misspecification does not exist, i.e., each player correctly understands the opponent's view about the world. There are two players $i = 1, 2$ and infinitely many periods $t = 1, 2, \dots$. At the beginning of the game, an unobservable economic state θ^* is drawn from a closed interval $\Theta = [\underline{\theta}, \bar{\theta}]$, according to a common prior distri-

³ Benaïm (1999) also prove a similar non-convergence theorem, but his result does not apply to our model for the same reason. Benaïm and Faure (2012) prove a non-convergence result which allows a Gaussian noise, but they assume that the process is cooperative. Furthermore, they make various assumptions on the noise term, which are not satisfied in our model (e.g., i.i.d. noise, positive-definite assumption which rules out perfect correlation of a noise).

bution $\mu \in \Delta\Theta$. We assume that μ has a continuous density μ' with full support. In each period t , each player i has a belief $\mu_i^t \in \Delta\Theta$ about the state θ , and chooses an action x_i from a closed interval $X_i = [0, \bar{x}_i]$. Player i 's action x_i is not observable by the opponent $j \neq i$. Given an action profile $x = (x_1, x_2)$, the players observe a noisy public signal $y = Q(x_1, x_2, a, \theta^*) + \varepsilon$, where $a \in \mathbf{R}$ is a fixed parameter and ε is a random noise which follows the standard normal distribution $N(0, 1)$. Player i 's stage-game payoff is $u_i(x_i, y)$. We assume that both Q and u_i are twice continuously differentiable.

Crucially, we assume that one of the players (player 2) incorrectly believes that the true parameter is $A \neq a$, while the other player is unbiased and knows the parameter a . These first-order beliefs (about the parameter a) are common knowledge, e.g., player 1 knows that player 2 believes that the true parameter is $A \neq a$. We call it *first-order misspecification*, because player 2 has an incorrect first-order belief about the parameter a .

Player 1's subjective expected stage-game payoff given an action profile x and a state θ is

$$U_1(x, \theta) = E[u_1(x_1, Q(x, a, \theta) + \varepsilon)]$$

and player 2's subjective expected stage-game payoff is

$$U_2(x, A, \theta) = E[u_2(x_2, Q(x, A, \theta) + \varepsilon)],$$

where the expectation is taken with respect to ε . Note that player 2 evaluates payoffs given her subjective signal distribution $Q(x, A, \theta) + \varepsilon$. To economize notation, we will write $U_2(x, \theta)$ instead of $U_2(x, A, \theta)$ when it does not cause a confusion.

We assume that players play a static Nash equilibrium every period. This essentially means that in our model, (i) players are myopic, and (ii) they predict the opponent's play correctly and best-respond to it. Condition (i) shuts down the repeated-game effect, so that a result similar to the folk theorem (which is not of our interest) does not arise.⁴ Condition (ii) implies that players recognize that the opponent also learns the state and changes the action as time goes. This setup

⁴ Another way to avoid the repeated-game effect is to use a Markov-perfect equilibrium (where the state is players' beliefs about θ) as a solution concept, and with an additional assumption, we can show that players' long-run behavior is exactly the same as that of myopic players studied in this section. In this sense, our result remains true even for forward-looking players.

is different from the one in the literature on learning in games (e.g., Fudenberg and Kreps, 1993; Esponda and Pouzo, 2016), which asks when and why players play equilibria; they assume that players do not know the opponent's strategy and learn it from experience. In our model, players know the opponent's strategy, and learn only the unknown economic state θ .⁵

In period one, players play a Nash equilibrium (x_1^1, x_2^1) . Assuming an interior solution, it is an action profile which solves the first-order condition $\frac{\partial E[U_i(x, \theta) | \mu]}{\partial x_i} = 0$ for each i . At the end of period one, players observe a public signal y^1 , and update the posterior beliefs using Bayes' rule. Assuming that no one has deviated in period one, each player i 's posterior belief μ_1^2, μ_2^2 in period two is

$$\mu_1^2(\theta) = \frac{\mu_1^1(\theta) f(y - Q(x^1, a, \theta))}{\int_{\Theta} \mu_1^1(\tilde{\theta}) f(y - Q(x^1, a, \tilde{\theta})) d\tilde{\theta}} \quad \text{and} \quad \mu_2^2(\theta) = \frac{\mu_2^1(\theta) f(y - Q(x^1, A, \theta))}{\int_{\Theta} \mu_2^1(\tilde{\theta}) f(y - Q(x^1, A, \tilde{\theta})) d\tilde{\theta}},$$

where x^1 is the Nash equilibrium played in period one and f is the density function of the noise term ε . Note that player 2's posterior μ_2^2 differs from player 1's posterior μ_1^2 , as she incorrectly believes that the mean output is $Q(x^1, A, \theta)$ rather than $Q(x^1, a, \theta)$. Because the players' information structure about the parameter a is common knowledge, these posteriors are common knowledge among players. So in period two, players play a Nash equilibrium given the belief profile $\mu^2 = (\mu_1^2, \mu_2^2)$, which solves $\frac{\partial E[U_i(x, \theta) | \mu_i^2]}{\partial x_i} = 0$ for each i . Likewise, in any subsequent period t , players play a Nash equilibrium given the belief profile $\mu^t = (\mu_1^t, \mu_2^t)$, where μ^t is computed by Bayes' rule.

A *steady state* in this dynamic learning model is a pair $(x_1^*, x_2^*, \mu_1^*, \mu_2^*)$ of an action profile and a belief profile which satisfies the following four conditions:

$$x_1^* \in \arg \max_{x_1} U_1(x_1, x_2^*, \theta^*), \tag{1}$$

$$x_2^* \in \arg \max_{x_2} U_2(x_1^*, x_2, \theta_2), \tag{2}$$

$$\mu_1^* = 1_{\theta^*}, \tag{3}$$

$$\mu_2^* = 1_{\theta_2} \text{ s.t. } \theta_2 \in \arg \min_{\theta \in \Theta} |Q(x^*, A, \theta) - Q(x^*, a, \theta^*)|. \tag{4}$$

⁵ Condition (ii) is inessential if the game is dominance solvable. Note that all the examples studied in this paper are actually dominance solvable.

The first two conditions (1) and (2) are incentive compatibility, which requires that each player maximizes her payoff given some beliefs. The other two conditions require that these beliefs satisfy consistency: (3) asserts that the unbiased player 1 correctly learns the true state θ^* in a steady state. (4) requires that player 2's belief is concentrated on a state θ_2 which best explains the data, in that with this state θ_2 , player 2's subjective view about the mean output is closest to the actual mean. This condition must be satisfied in a steady state; otherwise, player 2 is “surprised” by observed signals and her belief will move to the state which better explains the data. In many economic applications (including the environmental problem example in the next subsection), the consistency condition (4) reduces to

$$Q(x^*, A, \theta_2) = Q(x^*, a, \theta^*), \quad (5)$$

i.e., the subjective mean output exactly matches the true mean.

As we show in our companion paper (Murooka and Yamamoto, 2023), if there is a unique steady state and if a mild condition called *identifiability* is satisfied, then players' actions and beliefs converge to this steady state almost surely.⁶ So the steady state can be thought of as a “long-run outcome” of the dynamic learning model.

Note that in most economic applications (including all the examples studied in this paper), the steady-state outcome is continuous with respect to the parameter A . So a small misspecification leads to approximately correct learning of the state θ , i.e., player 2's steady-state belief θ_2 is close to the true state θ^* when the parameter A is close to a .

2.2 Application: Optimism in Environmental Problems

To see how the steady state looks like, we will consider a model of environmental problems, which includes air pollution, deforestation, and fishery as special cases.⁷ Every period, each player $i = 1, 2$ chooses a production level $x_i \in [0, 1]$, which has a negative impact on the quality of the

⁶ The identifiability condition requires that given any action frequency $\sigma \in \Delta X$, there is a unique state θ which minimizes the Kullback-Leibler divergence between the true signal distribution and the subjective signal distribution. See Murooka and Yamamoto (2023).

⁷ More generally, this is a model of production with negative externalities.

environment. As in Chapter 24 of Varian (1992), we assume that the quality of the environment is given by the formula

$$y = Q(x, a, \theta) + \varepsilon = a - \theta(x_1 + x_2) + \varepsilon, \quad (6)$$

where $a \in \mathbf{R}$ is a fixed parameter, $\theta \in \Theta = [0.7, 0.9]$ is an unknown fundamental, and ε is a noise term which follows the standard normal distribution $N(0, 1)$. Player i 's payoff is $y + x_i - c(x_i)$, where x_i is a private benefit from production and $c(x_i) = \frac{1}{2}x_i^2$ is a production cost. Since we assume $\theta \in (0, 1)$, regardless of players' beliefs, the Nash equilibrium in the one-shot game is an interior point. In what follows, we will assume that the true state is $\theta^* = 0.8$.

We assume that one of the players is unrealistically optimistic about the quality of the environment. Formally, we assume that player 2 incorrectly believes that the true parameter is $A > a$. Such optimism is commonly observed in various environmental problems, see Dechezleprêtre et al. (2022) and references therein.

This example satisfies the identifiability condition of Murooka and Yamamoto (2023), and hence regardless of the initial prior, the players' actions and beliefs almost surely converge to the steady state, which is characterized by (1)-(4). We will consider how player 2's bias influences this steady-state outcome.

Let Q_z denote the derivative of Q with respect to a variable z . Since $Q_a > 0$ and $Q_\theta < 0$, Condition (5) implies that player 2's steady-state belief is $\theta_2 > \theta^*$, i.e., the optimistic player overestimates the state in the long run. Intuitively, player 2 is disappointed by observed environmental quality being worse than the anticipation, and becomes pessimistic about the state θ as time goes. This in turn implies that player 2 overestimates the marginal social cost Q_{x_i} of the production.⁸ Thus, her steady-state action x_2 is lower than in the correctly-specified case. On the other hand, the unbiased player 1's production is exactly the same as in the correctly-specified case, because player 1's optimal production is independent of the opponent's action. Accordingly, player 2's payoff is lower than in the correctly-specified case, while player 1's payoff is higher than that. So player 2's bias is detrimental for herself, but *improves* the opponent's payoff. Also, simple algebra

⁸ Attari et al. (2010) report that people overestimate certain energy-saving activities (e.g., driving less to save gasoline), but their answers also have substantial variation.

shows that the latter effect is larger than the former effect, so player 2's bias improves the social surplus.

3 Higher-Order Misspecification

The benchmark model in the previous section assumed that players correctly understand the opponent's view about the world. Now we consider the case in which players have *higher-order misspecification*, in that they have a biased view about the opponent's view about the world (second-order misspecification), a biased view about the opponent's second-order misspecification, and so on.⁹

In what follows, we will focus on a special form of higher-order misspecification: We will assume that each player has a biased view about the world, and on top of that, she naively thinks that the opponent shares the same view about the world (in reality, the opponent has her own view about the world). We call it *double misspecification*, because players have a biased view about the world (first-order misspecification) and a biased view about the opponent's view about the world (second-order misspecification). Of course, we can think of various other forms of higher-order misspecification. In our companion paper Murooka and Yamamoto (2023), we present a more general model of higher-order misspecification.¹⁰

3.1 Setup: Double Misspecification

Our model is the same as the one studied in Section 2.1, except the information structure; now we will assume that each player i (incorrectly) believes that it is common knowledge that the signal y is given by $y = Q(x_1, x_2, A_i, \theta) + \varepsilon$. We allow $A_1 \neq A_2$, so the different players may have different levels of misspecification.

⁹ As evidence from laboratory experiments, subjects often systematically mispredict other subjects' preferences and actions (e.g., Van Boven, Dunning, and Loewenstein, 2000). Ludwig and Nafziger (2011) report that most subjects in their experiments are not aware of or underestimate overconfidence of other subjects.

¹⁰ In static games with strategic complementarity/substitutability, recent work by McGee (2023) analyzes how certain higher-order misspecification affects equilibrium outcomes.

A critical difference from the first-order misspecification is that players have *inferential naivety* and make incorrect predictions about the opponent's play.¹¹ Indeed, while player i believes that the opponent (player j) maximizes the payoff conditional on the parameter A_i , the opponent maximizes the payoff conditional on the parameter A_j in reality. Accordingly, player i 's prediction about the opponent's action does not match the opponent's actual action in general.

To analyze players' behavior in the presence of such inferential naivety, it is useful to consider two *hypothetical players* $i = 1, 2$. Hypothetical player i is player j who thinks that it is common knowledge that the true technology is A_j . Intuitively, player j thinks that hypothetical player i is her opponent, and hence each period, player j chooses a Nash equilibrium action against hypothetical player i .

Let \hat{x}_i and $\hat{\mu}_i$ denote hypothetical player i 's action and belief, and let $x = (x_1, x_2, \hat{x}_1, \hat{x}_2)$ denote an action profile in the four-player game. Player i 's expected stage-game payoff is defined as

$$U_i(x, \theta, A_i) = E[u_i(x_i, Q(x_i, \hat{x}_{-i}, A_i, \theta) + \varepsilon)],$$

because she thinks that the parameter is A_i and the opponent is a hypothetical player. Similarly, hypothetical player i 's expected stage-game payoff given θ is

$$\hat{U}_i(x, \theta, A_{-i}) = E[u_i(\hat{x}_i, Q(\hat{x}_i, x_{-i}, A_{-i}, \theta) + \varepsilon)].$$

Using these notations, the equilibrium strategy in the infinite-horizon game is described as follows. In period one, all players have the same belief $\mu_i^1 = \hat{\mu}_i^1 = \mu$. So they play a Nash equilibrium $(x_1^1, x_2^1, \hat{x}_1^1, \hat{x}_2^1)$, which (assuming interior solutions) satisfies the first-order conditions $\frac{\partial E[U_i(x, \theta) | \mu]}{\partial x_i} = 0$ and $\frac{\partial E[\hat{U}_i(x, \theta) | \mu]}{\partial \hat{x}_i} = 0$. At the end of period one, players observe a public signal $y^1 = Q(x_1^1, x_2^1, a, \theta^*) + \varepsilon$, and update the posterior beliefs using Bayes' rule. Their beliefs in period two are given by

$$\begin{aligned} \mu_i^2(\theta) &= \frac{\mu_i^1(\theta) f(y - Q(x_i^1, \hat{x}_{-i}^1, A_i, \theta))}{\int_{\Theta} \mu_i^1(\tilde{\theta}) f(y - Q(x_i^1, \hat{x}_{-i}^1, A_i, \tilde{\theta})) d\tilde{\theta}}, \\ \hat{\mu}_i^2(\theta) &= \frac{\hat{\mu}_i^1(\theta) f(y - Q(\hat{x}_i^1, x_{-i}^1, A_{-i}, \theta))}{\int_{\Theta} \hat{\mu}_i^1(\tilde{\theta}) f(y - Q(\hat{x}_i^1, x_{-i}^1, A_{-i}, \tilde{\theta})) d\tilde{\theta}}. \end{aligned}$$

¹¹ See Eyster (2019) for a review of the literature.

As is clear from this formula, player i 's posterior belief is biased in two ways: She updates the belief conditional on the wrong parameter A_i , and on the wrong prediction \hat{x}_{-i}^1 about the opponent's play. Then in period two, players play a Nash equilibrium given this belief profile $\mu^2 = (\mu_1^2, \mu_2^2, \hat{\mu}_1^2, \hat{\mu}_2^2)$.¹² Likewise, in any subsequent period t , players play a Nash equilibrium given the posterior beliefs computed by Bayes' rule.

Given an action profile $x = (x_1, x_2, \hat{x}_1, \hat{x}_2)$, let $\theta_i(x, A_i)$ denote player i 's long-run belief when the same action x is chosen every period. That is, let $\theta_i(x, A_i)$ be a state θ which solves

$$\min_{\theta \in \Theta} |Q(x_i, \hat{x}_j, A_i, \theta) - Q(x_1, x_2, a, \theta^*)|.$$

Note that the term $Q(x_i, \hat{x}_j, A_i, \theta)$ is player i 's subjective mean output given θ , while the term $Q(x_1, x_2, a, \theta^*)$ is the true mean. So $\theta_i(x, A_i)$ defined above is the state which best explains the data, given an action profile x . We will assume that $\theta_2(x, A)$ is unique for each x and A_i .

With this notation, a *steady state* under double misspecification is defined as $(x_1^*, x_2^*, \hat{x}_1^*, \hat{x}_2^*, \mu_1^*, \mu_2^*, \hat{\mu}_1^*, \hat{\mu}_2^*)$ which satisfies

$$x_i^* \in \arg \max_{x_i} U_i(x_i, \hat{x}_{-i}^*, A_i, \theta_i) \quad \forall i, \quad (7)$$

$$\hat{x}_i^* \in \arg \max_{\hat{x}_i} \hat{U}_i(\hat{x}_i, x_{-i}^*, A_{-i}, \theta_{-i}) \quad \forall i, \quad (8)$$

$$\mu_1^* = \hat{\mu}_2^* = 1_{\theta_1(x^*, A_1)}, \quad (9)$$

$$\mu_2^* = \hat{\mu}_1^* = 1_{\theta_2(x^*, A_2)}. \quad (10)$$

The first two conditions are the incentive-compatibility conditions, which require that each player maximize her own payoff given some beliefs. The next two conditions require that these beliefs satisfy consistency, in that each (actual and hypothetical) player's belief is concentrated on a state with which best explains the data.

¹² Since y is public, player 1 correctly predicts hypothetical player 2's posterior belief $\hat{\mu}_2^2$, and similarly, hypothetical player 2 correctly predicts player 1's posterior belief μ_1^2 . So they will indeed play a Nash equilibrium given these beliefs.

3.2 Environmental Problem under Double Misspecification

Consider the environmental problem discussed in Section 2.2, but assume now that players are not aware of the fact that the opponent has a different view about the world. Specifically, we consider double misspecification with parameters $A_1 = a$ and $A_2 \geq a$. Note that in this setup, player 1 is also misspecified; she has a correct view about the parameter a , but she is unaware of player 2's optimism and naively thinks that player 2 also knows a . To simplify the exposition, assume that the initial prior is a uniform distribution on $\Theta = [0.7, 0.9]$.

The steady state in this setup is characterized by the conditions (7)-(10). For the special case in which $A_1 = A_2 = a$ (i.e., the case with no misspecification), there are three steady states: One of the steady state is an interior point, in which both players learn the true state ($\theta_1 = \theta_2 = \theta^*$), and choose the Nash equilibrium for this state θ^* . The remaining two steady states are boundary points. In these steady states, players' beliefs are $(\theta_1, \theta_2) = (\underline{\theta}, \bar{\theta})$ or $(\theta_1, \theta_2) = (\bar{\theta}, \underline{\theta})$, and they choose a Nash equilibrium given these beliefs.¹³ These boundary steady states are not essential, in that they do not arise as a long-run outcome. Indeed, because there is no misspecification, starting from a common prior μ , players learn the true state with probability one, i.e., the beliefs converge to the interior steady state almost surely when $A_1 = A_2 = a$.

Now, consider the case in which player 2 is slightly optimistic (i.e., A_2 is a bit larger than a). By the continuity, there is an interior steady state in which players' beliefs are close to (θ^*, θ^*) . Let $m^* = (m_1^*, m_2^*)$ denote this steady-state belief. Also, the boundary points $(\theta_1, \theta_2) = (\underline{\theta}, \bar{\theta})$ and $(\theta_1, \theta_2) = (\bar{\theta}, \underline{\theta})$ are still steady states in this case.

One may expect that the boundary states are still inessential as in the case of no misspecification, and that the the beliefs converge to the interior steady state m^* , just as in the case of no misspecification. Proposition 1 shows that such a conjecture is incorrect, and the beliefs converge to the boundary points when $A_2 > a$.

¹³ To see that $(\theta_1, \theta_2) = (\underline{\theta}, \bar{\theta})$ is a steady-state belief, note that $\frac{\partial^2 Q}{\partial x_i \partial \theta} < 0$, so we have $x_1 > \hat{x}_1$ in this steady state. This means that player 2 underestimates the opponent's production, and thus finds that the quality of the environment is worse than the anticipation. This makes player 2 more pessimistic, but her current belief $\bar{\theta}$ already hits the upper bound of the set Θ , so her belief stays there. Similarly, player 1's belief stays at $\underline{\theta}$, which imply that $(\theta_1, \theta_2) = (\underline{\theta}, \bar{\theta})$ is indeed a steady-state belief. For the same reason, $(\theta_1, \theta_2) = (\bar{\theta}, \underline{\theta})$ is a steady-state belief.

Proposition 1. (i) Suppose that $A_2 = a$. Then almost surely, players eventually learn the true state θ^* , i.e.,

$$\Pr\left(\lim_{t \rightarrow \infty} (\mu_1^t, \mu_2^t) = (1_{\theta^*}, 1_{\theta^*})\right) = 1.$$

(ii) There is $\bar{A}_2 > a$ such that for any $A_2 \in (a, \bar{A}_2)$, players' posterior beliefs $\mu^t = (\mu_1^t, \mu_2^t)$ converge to the interior steady state $(1_{m_1^*}, 1_{m_2^*})$ with zero probability. Indeed, almost surely, the beliefs converge to the boundary points, i.e.,

$$\Pr\left(\lim_{t \rightarrow \infty} \mu^t \in \{(1_{\underline{\theta}}, 1_{\bar{\theta}}), (1_{\bar{\theta}}, 1_{\underline{\theta}})\}\right) = 1.$$

Proposition 1 shows that unawareness about the opponent's bias can have a huge impact on the equilibrium outcome. Recall that in the case of first-order misspecification, small optimism of player 2 has only a marginal impact on the long-run outcome, and players approximately learn the true state. In contrast, when players are unaware of the opponent having a different view about the world, the long-run outcome becomes discontinuous at $A_2 = a$, and even vanishingly small optimism completely changes the learning outcome.

In the literature of incomplete-information games, it is well-known that an equilibrium in a normal-form game is continuous with respect to the information structure; Chen, Di Tillio, Faingold, and Xiong (2017) show that a small perturbation of one's belief hierarchy (a belief about an economic state, a belief about the opponent's belief about the state, and so on) has only a marginal impact on the equilibrium. Our Proposition 1 above does not contradict with this result. Indeed, in our model, the *equilibrium strategy* in the infinite-horizon game, which maps one's belief μ_i to an action, is continuous in the parameter A_2 , so a small perturbation of one's belief hierarchy has a negligible impact on the equilibrium strategy.¹⁴ In this sense, the main result of Chen, Di Tillio, Faingold, and Xiong (2017) still holds in our model. However, this need not imply that the resulting *equilibrium outcome* is continuous in the parameter A_2 , and Proposition 1 shows that our model is one of the cases in which such discontinuity arises.

¹⁴ In our model, the belief hierarchies induced by A_2 and $A_2' \neq A_2$ are close in the uniform-weak topology of Chen, Di Tillio, Faingold, and Xiong (2017) if A_2 and A_2' are close.

3.3 Proof Sketch of Proposition 1

Now we will describe an outline of the proof of Proposition 1 (ii). Given an action profile $x = (x_1, x_2, \hat{x}_1, \hat{x}_2)$, player i believes that the signal y is generated by the formula

$$y = A_i - \theta(x_i + \hat{x}_{-i}) + \varepsilon$$

which can be rewritten as

$$\theta - \frac{\varepsilon}{x_i + \hat{x}_{-i}} = \frac{A_i - y}{x_i + \hat{x}_{-i}}.$$

Hence, if she observes a signal y , then the likelihood of the state $\theta \in \Theta$ is the truncated normal distribution on the set Θ , induced by a normal distribution with mean $\frac{A_i - y}{x_i + \hat{x}_{-i}}$ and variance $\left(\frac{1}{x_i + \hat{x}_{-i}}\right)^2$.¹⁵ For shorthand notation, let $I_i(x)$ denote the inverse of this variance, i.e.,

$$I_i(x) = (x_i + \hat{x}_{-i})^2.$$

Intuitively, this $I_i(x)$ measures the informativeness of the signal y for player i given an action profile x ; high I_i implies low variance, meaning that the signal is more informative.

Since the initial prior is uniform and the likelihood induced by signals is truncated normal, each player's posterior belief is also a truncated normal distribution. Let $\tilde{N}(m, \sigma^2)$ denote the truncated normal distribution induced by the normal distribution $N(m, \sigma^2)$. Then player i 's posterior at the beginning of period $t + 1$ is the truncated normal distribution $\tilde{N}(m_i^{t+1}, \frac{1}{t\xi_i^{t+1}})$, where the parameters m_i^{t+1} and ξ_i^{t+1} are given by

$$m_i^{t+1} = \frac{\sum_{\tau=1}^t I_i(x_i^\tau, \hat{x}_{-i}^\tau) \left(\frac{A_i - y^\tau}{x_i^\tau + \hat{x}_{-i}^\tau} \right)}{\sum_{\tau=1}^t I_i(x_i^\tau, \hat{x}_{-i}^\tau)}, \quad (11)$$

$$\xi_i^{t+1} = \frac{1}{t} \sum_{\tau=1}^t I_i(x_i^\tau, \hat{x}_{-i}^\tau). \quad (12)$$

In words, the parameter m_i^{t+1} is the weighted average of player i 's estimate $\frac{A_i - y^\tau}{x_i^\tau + \hat{x}_{-i}^\tau}$ each period, where the weight is the informativeness I_i . The parameter ξ_i^{t+1} is simply the average of the informativeness I_i of the past signals. Our goal is to show that this posterior belief $\tilde{N}(m_i^{t+1}, \frac{1}{t\xi_i^{t+1}})$ does not converge to the interior steady state.

¹⁵ The truncated normal distribution is derived from a normally distributed random variable by bounding the random variable from either below or above (or both). For example, when a random variable X follows $N(\mu, \frac{1}{\xi})$, the truncated normal distribution on $\Theta = [\underline{\theta}, \bar{\theta}]$ is obtained by conditioning X on $\underline{\theta} \leq X \leq \bar{\theta}$.

Step 1: Difference Equation We first show that the motion of the parameters (m_i^t, ξ_i^t) can be described by a system of difference equations. Given an action profile x , let $\theta_i(x)$ be a solution to $Q(x_i, \hat{x}_{-i}, A_i, \theta) = Q(x_1, x_2, a, \theta^*)$, i.e.,

$$\theta_i(x) = \frac{A_i - a + \theta^*(x_1 + x_2)}{x_i + \hat{x}_{-i}}.$$

Intuitively, this $\theta_i(x)$ can be thought of as player i 's estimate of θ when the noise is zero (i.e., $\varepsilon = 0$).¹⁶ This suggests that player i 's actual estimate $\frac{A_i - y}{x_i + \hat{x}_{-i}}$ appearing in (11) can be represented as $\theta_i(x)$ plus a noise, and we indeed have¹⁷

$$\frac{A_i - y}{x_i + \hat{x}_{-i}} = \theta_i(x) - \frac{\varepsilon}{\sqrt{I_i(x_i, \hat{x}_{-i})}}.$$

Plugging the above equation into (11) and arranging it and (12), we obtain the following recursive equations which completely describe the evolution of (m^t, ξ^t) .

$$m_i^{t+1} - m_i^t = \frac{1}{t} \left\{ \frac{I_i(x_i^t, \hat{x}_{-i}^t) \left(\theta_i(x^t) - m_i^t - \frac{\varepsilon^t}{\sqrt{I_i(x_i^t, \hat{x}_{-i}^t)}} \right)}{\frac{t-1}{t} \xi_i^t + \frac{1}{t} I_i(x_i^t, \hat{x}_{-i}^t)} \right\}, \quad (13)$$

$$\xi_i^{t+1} - \xi_i^t = \frac{1}{t} (I_i(x_i^t, \hat{x}_{-i}^t) - \xi_i^t). \quad (14)$$

In words, (13) implies that player i updates the mean belief m_i^t depending on how her estimate $\theta_i(x^t) - \frac{\varepsilon^t}{\sqrt{I_i(x_i^t, \hat{x}_{-i}^t)}}$ based on the new information today differs from her current mean belief m_i^t . If the new estimate coincides with the current mean belief, she does not update it. Otherwise, the mean belief moves toward the new estimate $\theta_i(x^t) - \frac{\varepsilon^t}{\sqrt{I_i(x_i^t, \hat{x}_{-i}^t)}}$, and its magnitude is influenced by the informativeness of the signals; if $I_i(x_i^t, \hat{x}_{-i}^t)$ is relatively larger than $\frac{t-1}{t} \xi_i^t + \frac{1}{t} I_i(x_i^t, \hat{x}_{-i}^t)$, it means that the signal today is more informative relative to the past signals, and hence influences the posterior more.

The second equation (14) has a similar interpretation, and ξ_i^t is updated depending on how the informativeness $I_i(x_i^t, \hat{x}_{-i}^t)$ of the signal today differs from the informativeness ξ_i^t of the past signals.

¹⁶ For some x , $\theta_i(x)$ defined above may not be in the state space Θ . So $\theta_i(x)$ should be regarded as a parameter which best explains the data, *when the choice of θ is not restricted on the state space Θ* . In contrast, $\theta_i(x, A_i)$ defined in the previous subsection must be chosen from the state space Θ .

¹⁷ This equation follows from the definition of $\theta_i(x)$ and $y = a - \theta^*(x_1 + x_2) + \varepsilon$.

Note that players' actions (x_i^t, \hat{x}_{-i}^t) in period t is a one-shot Nash equilibrium given the posterior belief $\tilde{N}(m_i^t, \frac{1}{(t-1)\xi_i^t})$, so all terms in the right-hand sides of the above equations are the functions of (m_i^t, ξ_i^t) , except the noise term ε^t . Hence the above difference equations are indeed recursive, i.e., once we fix the current value (m_i^t, ξ_i^t) and the noise term ε^t , the next value (m_i^{t+1}, ξ_i^{t+1}) is uniquely determined.

Step 2: Stochastic Approximation Since the difference equations derived in Step 1 involves a stochastic noise term ε , finding its exact solution is a hard problem. So instead, we borrow the idea of stochastic approximation and use the fact that the solution to the difference equations can be approximated by much simpler *differential equations*.

Recall that player i 's posterior belief in period t is the truncated normal distribution $\tilde{N}(m_i^t, \frac{1}{(t-1)\xi_i^t})$, where m_i^t is the mean and $\frac{1}{(t-1)\xi_i^t}$ is the variance of the (untruncated) normal distribution. When t is sufficiently large, this variance $\frac{1}{(t-1)\xi_i^t}$ approaches zero, and hence the belief $\tilde{N}(m_i^t, \frac{1}{(t-1)\xi_i^t})$ is approximately a degenerate belief. Given m_i , let $\tilde{N}(m, 0)$ denote this limiting belief, that is,

$$\tilde{N}(m, 0) = \lim_{\sigma^2 \rightarrow 0} \tilde{N}(m, \sigma^2) = \begin{cases} 1_m & \text{if } m \in [\underline{\theta}, \bar{\theta}] \\ 1_{\underline{\theta}} & \text{if } m < \underline{\theta} \\ 1_{\bar{\theta}} & \text{if } m > \bar{\theta} \end{cases}$$

where $\underline{\theta} = 0.7$ and $\bar{\theta} = 0.9$ denote the boundary points of the state space $\Theta = [0.7, 0.9]$.

Then players' actions (x_i^t, \hat{x}_{-i}^t) in period t can be approximated by the one-shot Nash equilibrium given this limiting belief $\tilde{N}(m_i^t, 0)$. Let $\theta_i(m_1^t, m_2^t)$ and $I_i(m_i^t)$ denote player i 's estimate and the signal informativeness when players play this Nash equilibrium. That is, $\theta_i(m_1, m_2) = \theta_i(x)$ and $I_i(m_i) = I_i(x_i, \hat{x}_{-i})$, where $(\hat{x}_j, \hat{x}_{-j})$ is the Nash equilibrium for the belief $\tilde{N}(m_j, 0)$ for each j .

This in turn implies that the drift terms of the difference equations (13) and (14) are approximated by much simpler terms $\frac{I_i(m_i^t)(\theta_i(m^t) - m_i^t)}{\xi_i^t}$ and $I_i(m_i^t) - \xi_i^t$, in the sense that there is $K > 0$ such that for any t and for $\alpha = 0.5$,

$$\left| \frac{I_i(x_i^t, \hat{x}_{-i}^t)(\theta_i(x^t) - m_i^t)}{\frac{t-1}{t}\xi_i^t + \frac{1}{t}I_i(x_i^t, \hat{x}_{-i}^t)} - \frac{I_i(m_i^t)(\theta_i(m^t) - m_i^t)}{\xi_i^t} \right| < \frac{K}{t^\alpha}, \quad (15)$$

$$\left| (I_i(x_i^t, \hat{x}_{-i}^t) - \xi_i^t) - (I_i(m_i^t) - \xi_i^t) \right| < \frac{K}{t^\alpha}. \quad (16)$$

Then it follows from the theory of stochastic approximation (e.g., Theorem 2.1 of Kushner and Yin (2003)) that the asymptotic behavior of the process (13) and (14) is approximated by the ordinal differential equations (ODE)

$$\frac{dm_i(t)}{dt} = \frac{I_i(m_i(t))(\theta_i(m(t)) - m_i(t))}{\xi_i(t)}, \quad (17)$$

$$\frac{d\xi_i(t)}{dt} = I_i(m_i(t)) - \xi_i(t), \quad (18)$$

which do not involve a noise term.

Step 3: Instability of the Interior Steady State Figure 1 is the phase portrait which describes the solution to the ODE (17), when there is no misspecification (i.e., $A_2 = a$) and the variable $\xi(t)$ is fixed at $\xi_1(t) = \xi_2(t) = 1$ for all t .¹⁸ The origin is the point in which both players learn the true state (i.e., $(m_1, m_2) = (\theta^*, \theta^*)$ where $\theta^* = 0.8$), which is the interior steady state in this special case. There are only two paths converging to this steady state m^* , one from the top-right and the one from bottom-left. These paths are the *basin of attraction* of the steady state. If the initial value is not on this basin of attraction, the solution to the ODE does not converge to m^* , and it moves toward the boundary points. (This is so even if the initial value is in a neighborhood of the origin.) In this sense, the origin is an *unstable* steady state.

Figure 2 is the phase portrait when player 2 is optimistic (precisely, when $A_2 - a = 0.03$). Due to the misspecification, the origin is not a steady state; now the steady state m^* moves toward the top-right corner. Other than that, the motion of the mean belief $m(t)$ is very similar to that for the case with no misspecification. In particular, the steady state m^* is still unstable, in that there are only two paths converging to this point.

The instability of the steady state m^* here is deeply related to the inferential naivety. To see this, note first that in the steady state m^* , each player's subjective output exactly matches the objective output. Suppose now that the mean belief is perturbed toward the bottom-right direction, and we have $m(t) = (m_1(t), m_2(t)) = (m_1^* + \eta, m_2^* - \eta)$ for small $\eta > 0$. That is, we consider the

¹⁸ In reality, the parameter ξ_i is *not* fixed, and evolves according to (18). However, this does not influence the motion of the mean belief $m(t)$ much, because the variable ξ does not influence the sign of $\frac{dm_i(t)}{dt}$ in the ODE (17), i.e., it does not influence whether the mean belief $m_i(t)$ increases or decreases at the next instant. Accordingly, the motion of $m(t)$ is very similar to the one described in Figure 1 even for the case in which $\xi(t)$ changes over time.

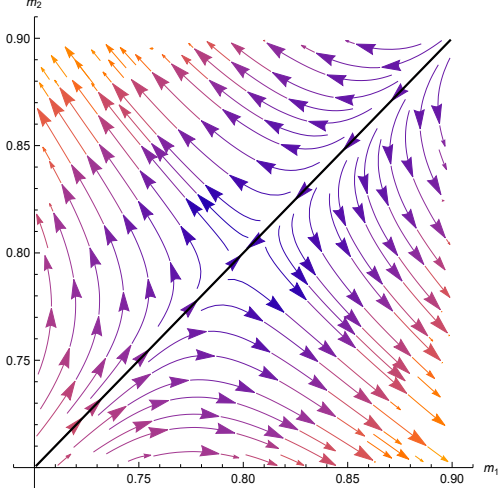

Figure 1: Motion of $m(t)$ when $A_2 = a$

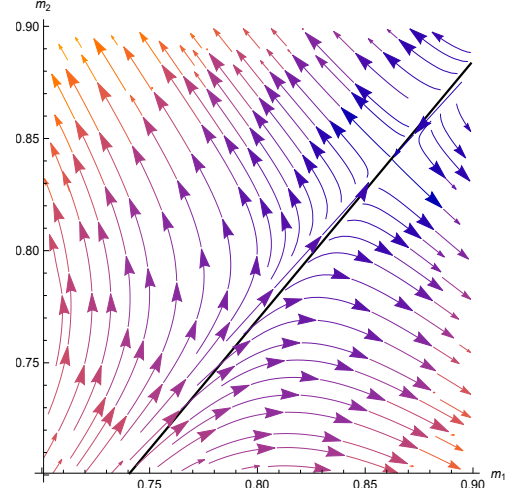

Figure 2: Motion of $m(t)$ when $A_2 > a$

case in which player 1 is more pessimistic about the state θ than in the steady state, while player 2 is more optimistic about the state. With this belief profile, player 1 reduces the production than in the steady state, while player 2 increases the production. However, due to the inferential naivety, player 1 misestimates the opponent's production; player 1 incorrectly believes that the opponent is similarly pessimistic and reduces the production (in reality, the opponent increases the production). This means that player 1 observes the environmental quality worse than her anticipation, and becomes even more pessimistic about the state θ . Similarly, player 2 becomes even more optimistic. Hence the gap between players' beliefs become larger, and the belief profile $m(t)$ moves toward the bottom-right corner, rather than moving back to the origin. This “amplifying effect” continues over and over; so even if the initial gap η is small, it becomes arbitrarily large, and the belief converges to the boundary point.

Remark 1. For the argument in the last paragraph of this step to work, it is critical that the state θ and one's belief about θ have conflicting effects on the outcome y , in the sense that Q_θ (which measures the effect of θ) and $Q_{x_i} \frac{\partial x_i}{\partial m_i}$ (which measures the effect of player i 's belief about θ through her action) have opposite signs. To see this, suppose that the current mean belief is $m(t) = (m_1(t), m_2(t)) = (m_1^* + \eta, m_2^* - \eta)$ as in the discussion above, and suppose now that $Q_\theta > 0$

and $Q_{x_i} \frac{\partial x_i}{\partial m_i} > 0$.¹⁹ The latter inequality implies that player 1’s inferential naivety leads her to overestimate the output, i.e., she finds that the actual output is worse than her anticipation. Then because we have $Q_\theta > 0$, player 1’s mean belief m_1 goes down and approaches to the steady state belief m_1^* . In Section 3.4, we will consider a general setup, and show that this property is indeed necessary for the instability. See Proposition 3.

Step 4: Non-Convergence to Unstable Steady State In the previous step, we have seen that the motion of the solution to the ODE is very sensitive to the initial value: If the initial value is on the basin of attraction of the interior steady state, the solution eventually converges to there. However, once the initial value is perturbed, the solution moves toward a different direction and converges to the boundary points. It turns out that this property is the key to obtain our discontinuity result.

To begin with, consider the case with $A_2 > a$, and suppose that the current mean belief m^t is at the steady state (or in its neighborhood). The key observation is that due to the stochastic shock ε , the mean belief m^t cannot stay at the basin of attraction of the steady state forever. Indeed, as can be seen from (13), the shock ε pushes m^t toward the direction

$$b = \left(\frac{\sqrt{I_1}}{(t-1)\xi_1 + I_1}, \frac{\sqrt{I_2}}{(t-1)\xi_2 + I_2} \right),$$

which is simplified to $b = (\frac{1}{t\sqrt{I_1}}, \frac{1}{t\sqrt{I_2}})$ in the steady state.²⁰ This vector b is represented by the black thick line in Figure 2, and it does not coincide with the basin of attraction of the steady state. Hence at some point, the mean belief m^t will be “kicked out” from the basin due to the shock, and then the mean belief should move toward the boundary points, rather than reverting to the steady state.²¹

In contrast, when there is no misspecification (i.e., $A_2 = a$), the mean belief m^t remains on the basin of attraction, even after the shock ε . Indeed, if the current mean belief is at the steady state,

¹⁹ Note that $Q_\theta < 0$ and $Q_{x_i} \frac{\partial x_i}{\partial m_i} > 0$ in the above example.

²⁰ Here we use the fact that $\xi_i = I_i$ at the steady state.

²¹ More precisely, in the proof of the non-convergence theorem, we show that the mean belief leaves $\frac{c}{\sqrt{t}}$ -neighborhood of the basin of attraction infinitely often, due to the shock ε . Once the mean belief leaves this neighborhood, the drift term (which represents the “amplifying effect” we explained in the last step) is bounded away from zero and dominates the impact of the stochastic shock ε , and hence the mean belief moves toward the boundary points as described in Figure 2.

the shock pushes the mean belief toward the direction

$$b = \left(\frac{1}{t\sqrt{I_1}}, \frac{1}{t\sqrt{I_2}} \right),$$

which is proportional to $(1, 1)$ in this special case. This means that the mean belief m^t remains on the 45-degree line, even after the shock. As can be seen from Figure 1, this 45-degree line is precisely the basin of attraction, and hence the solution to the ODE starting from the current mean belief reverts to the steady state. This suggests that the beliefs converge to the interior steady state in this case. Intuitively, in the case of no misspecification, player 1's posterior belief about θ coincides with player 2's belief after every history, and hence the amplifying effect is *never* triggered; accordingly the mean belief does not move toward the boundary points.

In the proof of Proposition 1, we formalize the idea above by borrowing a technique developed by Pemantle (1990), who establish a non-convergence theorem for a class of stochastic processes. Pemantle's theorem does not apply to our model directly, as our stochastic process does not satisfy some technical assumptions of Pemantle. So we extend Pemantle's result and show that the same result applies to our setup; see Appendix B for details.

Remark 2. Heidhues, Kőszegi, and Strack (2021) consider a single-agent learning problem and show that the agent's belief does not converge to an unstable steady state. Unfortunately, their proof has a flaw: In the proof, they show that the mean belief visits the basin of attraction of stable steady states infinitely often, but this need not imply non-convergence to unstable equilibria. (As shown in Theorem 6.10 of Benaïm (1999), we need to show that the mean belief visits a *compact subset* of the basin of stable steady states infinitely often.) However, their theorem is correct as is, and it is an immediate corollary of our non-convergence theorem in Appendix B. (So this is one of the examples in which our non-convergence theorem is valuable.)

3.4 Non-Convergence in a General Setup

We have seen that in the environmental problem under double misspecification, players' beliefs do not converge to the interior steady state. Now we will consider a general model and provide a condition under which discontinuity similar to that in the environmental problem occurs.

Consider a general model of double misspecification with a compact state space $\Theta = [\underline{\theta}, \bar{\theta}]$. Consider an initial prior μ with a continuous density. Assume that for any state θ , a Nash equilibrium (x_i, \hat{x}_{-i}) given (A_i, θ) is unique.

Assume that the output function Q is linear in θ , in that $Q = R(x, a)\theta + S(x, a)$, and define $I_i(x_i, \hat{x}_{-i}) = (R(x_i, \hat{x}_{-i}, A_i))^2$. This linearity assumption is a bit restrictive, but it ensures that the likelihood induced by any signal sequence (y^1, \dots, y^t) is the truncated normal distribution $\tilde{N}(m_i^t, \frac{1}{(t-1)\xi_i^t})$, where the parameters m_i^t and ξ_i^t are determined by (11) and (12) with the term $\frac{A_i - y^t}{x_i^t + \hat{x}_{-i}^t}$ in (11) being replaced by $\frac{y^t - S(x_i^t, \hat{x}_{-i}^t, A_i)}{R(x_i^t, \hat{x}_{-i}^t, A_i)}$. We assume that $R(x_i, \hat{x}_{-i}, A_i) \neq 0$ for all on-path actions (x_i, \hat{x}_{-i}) ; this implies that $\xi_i^t > 0$, and hence the distribution $\tilde{N}(m_i^t, \frac{1}{(t-1)\xi_i^t})$ is well-defined. To keep our notation as simple as possible, in what follows, we strengthen this assumption and focus on the case in which $R(x_i, \hat{x}_{-i}, A_i) < 0$ for all on-path actions (x_i, \hat{x}_{-i}) .²² Then just as in the environmental problem, the evolution of the parameters m_i^t and ξ_i^t is governed by the difference equations (13) and (14), where $\theta_i(x)$ is a solution to $Q(x_i, \hat{x}_{-i}, A_i, \theta) = Q(x_1, x_2, a, \theta^*)$.

Assume that the drift terms of these difference equations are approximated by the drift terms of the ODE. That is, assume that there is $K > 0$ and $\alpha > 0$ such that (15) and (16) hold. Then it follows from the theory of stochastic approximation that the evolution of the parameters (m^t, ξ^t) is asymptotically approximated by the ODE (17) and (18). Here, the functions $I_i(m_i^t)$ and $\theta_i(m^t)$ in these equations are defined as in the environmental problem (i.e., these are the informativeness $I_i(x_i, \hat{x}_{-i})$ and the estimate $\theta_i(x)$ when players have degenerate beliefs and play a Nash equilibrium given these beliefs).

A steady state of the ODE is a point $p = (m_1, m_2, \xi_1, \xi_2)$ where $\frac{dm_i(t)}{dt} = \frac{d\xi_i(t)}{dt} = 0$. A steady state p is *linearly unstable* if the Jacobian J of the ODE at the point p has at least one eigenvalue with positive real part. When p is linearly unstable, the basin of attraction of p is locally approximated by $p + H$, where H is the space spanned by the eigenvectors associated with eigenvalues with negative real parts. So if the initial value is not in this set $p + H$, the solution to the ODE eventually leaves a neighborhood of p . The interior steady state of the environmental problem in Section 3.2

²² When $R(x_i, \hat{x}_{-i}, A_i) > 0$ for some actions (x_i, \hat{x}_{-i}) , the term $-\varepsilon^t / \sqrt{I_i(m_i^t, \frac{1}{(t-1)\xi_i^t})}$ in (13) should be replaced with $+\varepsilon^t / \sqrt{I_i(m_i^t, \frac{1}{(t-1)\xi_i^t})}$ for such actions, and it may influence the specification of the vector b . All the remaining arguments are not affected.

is an example of linearly unstable steady states; as described in Figure 1, when $A_1 = A_2 = a$, the solution to the ODE leaves a neighborhood of the origin unless the initial value is on the 45-degree line.

In our general model, the set H , which determines the basin of attraction of the steady state, can be computed as follows: Note that $\theta_i(m) - m_i = 0$ and $\xi_i = I_i$ in any steady state. Hence the Jacobian J of the ODE at a steady state p can be written as

$$J = \begin{pmatrix} \frac{\partial \theta_1}{\partial m_1} - 1 & \frac{\partial \theta_1}{\partial m_2} & 0 & 0 \\ \frac{\partial \theta_2}{\partial m_1} & \frac{\partial \theta_2}{\partial m_2} - 1 & 0 & 0 \\ \frac{\partial I_1}{\partial m_1} & 0 & -1 & 0 \\ 0 & \frac{\partial I_2}{\partial m_2} & 0 & -1 \end{pmatrix}.$$

Obviously this Jacobian J has an eigenvalue $\lambda = -1$ (multiplicity 2), and the corresponding eigenspace is

$$\{(0, 0, \xi_1, \xi_2) \mid \forall \xi_1, \xi_2 \in \mathbf{R}\}. \quad (19)$$

The remaining two eigenvalues of J are the ones for the submatrix

$$J' = \begin{pmatrix} \frac{\partial \theta_1}{\partial m_1} - 1 & \frac{\partial \theta_1}{\partial m_2} \\ \frac{\partial \theta_2}{\partial m_1} & \frac{\partial \theta_2}{\partial m_2} - 1 \end{pmatrix}.$$

So a steady state p is linearly unstable if and only if this submatrix J' has an eigenvalue with positive real part.

If the two eigenvalues of J' have positive real part, then the set H is simply the set described by (19). So the solution to the ODE leaves a neighborhood of p , unless the mean belief (m_1, m_2) of the initial value exactly matches that of the steady-state belief. If the matrix J' has one eigenvalue with positive real part and one eigenvalue with negative real part, then the set H is

$$\{(ch_1, ch_2, \xi_1, \xi_2) \mid \forall c, \xi_1, \xi_2 \in \mathbf{R}\}$$

where $h = (h_1, h_2)$ is an eigenvector associated with the eigenvalue with negative real part. In this case, if the initial value of the mean belief (m_1, m_2) is perturbed toward a direction other than h , then it leaves the basin $p + H$, so that the solution to the ODE must leave a neighborhood of p .

The following proposition shows that the process does not converge to a linearly unstable steady state, if the noise kicks out the mean belief from its basin of attraction in the above sense. This result is a direct consequence of the general non-convergence theorem in Appendix B (Proposition 5), and hence we omit the proof. Let b denote the coefficient vector on the noise term ε in the difference equations (13) and (14) at the steady state p , i.e.,

$$b = \left(\frac{\sqrt{I_1}}{t\xi_1 + I_1}, \frac{\sqrt{I_2}}{t\xi_2 + I_2}, 0, 0 \right) = \frac{1}{t+1} \left(\frac{1}{\sqrt{I_1}}, \frac{1}{\sqrt{I_2}}, 0, 0 \right).$$

Proposition 2. *Pick the parameters (A_1, A_2) arbitrarily, and pick an initial prior μ with a continuous density. Let p be a linearly unstable steady state of the ODE (17) and (18). Assume that the following properties hold.*

- (i) *For each i and θ , a Nash equilibrium (x_i, \hat{x}_{-i}) given (A_i, θ) is unique.*
- (ii) *The noise term ε follows the standard normal distribution $N(0, 1)$,*
- (iii) *$Q = R(x, a)\theta + S(x, a)$ and $R < 0$ for all on-path actions.*
- (iv) *Given any on-path action profile x , there is a unique $\theta \in \mathbf{R}$ which solves $Q(x_i, \hat{x}_{-i}, A_i, \theta) = Q(x_1, x_2, a, \theta^*)$. (Hence $\theta_i(x)$ is well-defined.)*
- (v) *The functions $I_i(m_i)$ and $\theta_i(m)$ are Lipschitz-continuous.*
- (vi) *There is $K > 0$ such that (15) and (16) hold for $\alpha = 1$ at the steady state p .*
- (vii) *$b \notin H$.*

Then the probability of $\lim_{t \rightarrow \infty} (m^t, \xi^t) = p$ is zero.

The critical assumption in Proposition 2 is (vii), which implies that the process (m^t, ξ^t) cannot stay in the basin of attraction of p due to the stochastic shock ε . Proposition 2 asserts that if this assumption (as well as other standard assumptions (i)-(vi)) holds, then the process converges to the unstable steady state p with zero probability.

We view assumption (vii) as a mild restriction, because it is satisfied for generic choice of parameters. For example, in the environmental problem studied in the previous subsections, the

assumption (vii) is satisfied for any value $A_2 \neq a$ in a neighborhood of a . In this sense, linear instability of p “almost always” implies non-convergence to p .

So it is important to understand when an interior steady state p is linearly unstable, and the next proposition characterizes it. We use the following notation. For each i and θ_{-i} , let $f_i^*(\theta_{-i})$ denote the set of all θ_i such that $\theta_i = \theta_i(x, A_i)$ for some $(x_1, x_2, \hat{x}_1, \hat{x}_2)$ such that (x_i, \hat{x}_{-i}) is a Nash equilibrium given (A_i, θ_i) for each i . Intuitively, this $f_i^*(\theta_{-i})$ is the set of steady states in player i 's *single-agent learning problem*, where the opponent $-i$'s belief is fixed at θ_{-i} (and hence she chooses the same Nash equilibrium action for θ_{-i} every period), while player i incorrectly believes that the opponent $-i$'s belief changes over time.

Figure 3 describes the graph of f_i^* for the environmental problem. The blue line is the graph of $f_1^*(\theta_2)$. It shows that when θ_2 is fixed at a low value, we have $f_1^*(\theta_2) = \{\bar{\theta}_1\}$, i.e., the highest state $\bar{\theta}_1$ is the unique steady state for player 1's learning problem. Indeed, as can be seen from Figure 3, if θ_2 is low, the arrow points toward the east, so θ_1 goes up. Similarly, when θ_2 is fixed at a high value, we have $f_1^*(\theta_2) = \{\underline{\theta}_1\}$. When θ_2 takes an intermediate value, both boundary points $\underline{\theta}_1$ and $\bar{\theta}_1$ are still steady states, and on top of that, there is an interior steady state which is described by the upward-sloping blue curve in the figure. Note that at any point on this blue curve, the solution of the ODE moves toward the vertical direction only; i.e., player 1's belief m_1 does not change at the next instant. This means that these are indeed steady states for player 1's learning problem. The orange line in the figure is the graph of $f_2^*(\theta_1)$, and it can be interpreted in the same way. Note that a steady state of the joint learning problem is the intersections of the blue and orange lines.

Proposition 3. *Let $p = (m_1^*, m_2^*, \xi_1^*, \xi_2^*)$ be a steady state such that $Q(x_i, \hat{x}_{-i}, A_i, m_i^*) = Q(x_1, x_2, a, \theta^*)$ where $(x_1, x_2, \hat{x}_1, \hat{x}_2)$ denotes steady-state actions. Suppose also that for each i , there is an open interval U_i containing m_{-i}^* such that there is a unique continuous function $f_i : U_i \rightarrow \mathbf{R}$ with $f_i(m_{-i}^*) = m_i^*$ and $f_i(\theta_{-i}) \in f_i^*(\theta_{-i})$ for all $\theta_{-i} \in U_i$. Assume that f_i is differentiable. Then the following properties hold:*

- (i) *Suppose that $\frac{\partial \theta_i(m)}{\partial m_i} - 1 > 0$ at p for each i . Then p is linearly unstable.*
- (ii) *Suppose that $\frac{\partial \theta_i(m)}{\partial m_i} - 1 < 0$ at p for each i . Then p is linearly unstable if $f_1'(\theta_2)f_2'(\theta_1) > 1$ at p .*

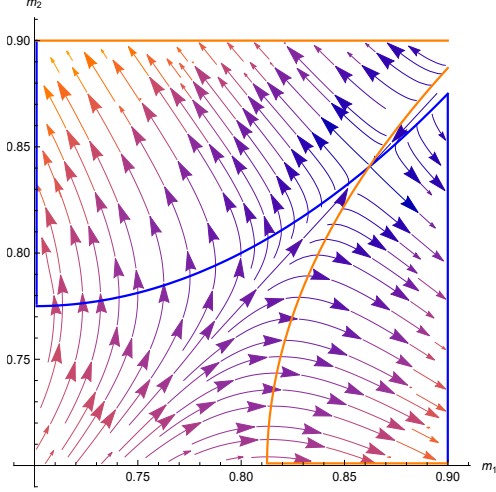

Figure 3: Example of $\frac{\partial \theta_i(m)}{\partial m_i} - 1 > 0$

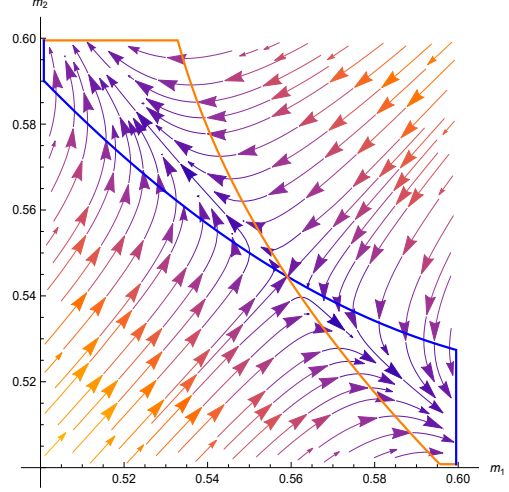

Figure 4: Example of $\frac{\partial \theta_i(m)}{\partial m_i} - 1 < 0$

The function f_i defined in Proposition 3 maps the opponent's belief θ_{-i} to player i 's interior steady-state belief. For example, in Figure 3, f_1 is the blue flatter upward-sloping curve, and f_2 is the orange steeper upward-sloping curve.

Proposition 3 (i) assumes $\frac{\partial \theta_i(m)}{\partial m_i} - 1 > 0$. To interpret this assumption, consider player i 's single-agent learning problem in which the opponent's belief is fixed at m_{-i}^* . In this problem, player i 's posterior belief is represented by the parameters (m_i^t, ξ_i^t) just as in the original problem, and the motion of (m_i^t, ξ_i^t) is approximated by the ODE (17) and (18). The Jacobian of this system of the ODE at the steady-state belief is

$$J_i = \begin{pmatrix} \frac{\partial \theta_i}{\partial m_i} - 1 & 0 \\ \frac{\partial I_i}{\partial m_i} & -1 \end{pmatrix},$$

so its eigenvalues are $\lambda = -1, \frac{\partial \theta_i}{\partial m_i} - 1$. The assumption $\frac{\partial \theta_i(m)}{\partial m_i} - 1 > 0$ ensures that the latter eigenvalue is positive, which means that the steady state is linearly unstable in this single-agent problem. Proposition 3 (i) shows that in such a case, the steady state is similarly unstable even when players jointly learn the state.

Proposition 3 (ii) assumes $\frac{\partial \theta_i(m)}{\partial m_i} - 1 < 0$, in which case the Jacobian J_i has two negative eigenvalues, $\lambda = -1, \frac{\partial \theta_i}{\partial m_i} - 1$. This means that in the single-agent learning problem, the steady state p is *asymptotically stable*; i.e., if the opponent's belief is fixed at the steady-state value, any solution

to the ODE starting from a neighborhood of p converges to p . Proposition 3 (ii) shows even in such a case, the steady state p can be unstable when players jointly learn the state. Specifically, if players' beliefs have strong complementarity/substitutability in that $f'_1 f'_2 > 1$, then the steady state is unstable. On the other hand, if $f'_1 f'_2 < 1$, then it is not difficult to show that the steady state is asymptotically stable, in that all eigenvalues of the Jacobian have negative real part. In this case, if the initial value is in a neighborhood of p , any solution to the ODE (17) and (18) converges to p .

The environmental problem studied in the previous subsections is one of the examples which satisfies the assumption stated in Proposition 3 (i). Indeed, as described in Figure 3, when $m_2(t)$ is fixed at the steady-state value and $m(t)$ moves on the horizontal axis only, the solution leaves a neighborhood of p . Hence the steady state p is unstable in the single-agent learning problem.

We can also construct an example which satisfies the assumption stated in Proposition 3 (ii), by replacing the parameters of the environmental problem with $\Theta = [0.5, 0.6]$ and $\theta^* = 0.55$. Figure 4 describes the solution of the ODE for this modified environmental problem with small optimism (specifically, $A_2 - a = 0.003$). Now the interior steady state is asymptotically stable in the single-agent learning problem; indeed, when $m_2(t)$ is fixed at the steady-state value and $m(t)$ moves on the horizontal axis only, the solution converges to p . Nonetheless this steady state is unstable in the joint learning problem, because the slope of the curve f_i is steep at the origin and $f'_1 f'_2 > 1$.

Proposition 3 is applicable to other economic applications as well. Here are two examples:

1. *Team production.* Suppose that two players work on a joint project. Each period, each player i chooses an effort level $x_i \in [0, 1]$ and observes an output

$$y = a - \theta \left(\frac{1}{x_1 + x_2} - \frac{1}{2} \right) + \varepsilon, \quad (20)$$

where a is the capability of the team, θ is an unknown state, and ε is a noise term which follows the standard normal distribution. Assume that the true state is $\theta^* = 0.5$. Player i 's payoff is $y - c(x_i)$, where $c(x_i) = \frac{1}{8}x_i^2$ is a production cost. Consider the double misspecification model with $A_1 = a$ and $A_2 > a$, where player 2 is overconfident about the capability and player 1 is unaware of it. When $A_2 = a$, simple algebra shows that $f'_1 f'_2 \approx 17.7$ at the interior steady state $\theta^* = 0.5$. By the continuity, this implies that $f'_1 f'_2 > 1$ for any A_2 close

to a . So from Proposition 3, the interior steady state is linearly unstable whenever player 2 has small overconfidence.

2. *Cournot duopoly with linear demand.* Suppose that each period, each firm $i = 1, 2$ chooses its quantity $x_i \in [0, \bar{x}]$, and a publicly observable market price is given by

$$y = a - \theta(x_1 + x_2) + \varepsilon,$$

where θ is an unknown state and ε is a noise term which follows the standard normal distribution. Firm i 's payoff is $yx_i - c(x_i)$, where yx_i is firm i 's revenue and $c(x_i)$ is firm i 's production cost. Consider the double misspecification model with $A_1 = a$ and $A_2 > a$, where firm 2 is overconfident about the demand and firm 1 is unaware of it. When $A_2 = a$, simple algebra shows that $f_1'f_2' > 1$ at the interior steady state $\theta^* = 0.5$ if and only if $c''(x_i) < 0$. By the continuity, the same is true for any $A_2 > a$ close to a . This means that if the cost function is strictly concave at the steady-state action, then player 2's small overconfidence leads to instability of the steady state.

As noted in Remark 1, for the steady state to be unstable in the environmental problem, it is critical that the state θ and one's belief about θ have conflicting effects on the output y . Proposition 3 implies that the same is true for a general setup, i.e., for a steady state to be unstable, it is necessary that $\frac{\partial Q}{\partial \theta}$ and $Q_{x_i} \frac{\partial x_i}{\partial m_i}$ have opposite signs, at least for symmetric games with small misspecification. Indeed, Proposition 3 asserts that in symmetric games with $A_1 = A_2 = a$, a steady state is unstable if $\frac{\partial \theta_i}{\partial m_i} > 1$ or $|f_i'(\theta_{-i})| > 1$.²³

²³ Although it is not stated in Proposition 3, it is straightforward to show that these conditions are necessary and sufficient for instability.

By the implicit function theorem, we have²⁴

$$\frac{\partial \theta_i}{\partial m_i} = -\frac{Q_{x_i} \frac{\partial x_i}{\partial m_i}}{Q_\theta} \quad \text{and} \quad f'_i(\theta_{-i}) = \frac{Q_{x_i} \frac{\partial x_i}{\partial m_i}}{Q_{x_i} \frac{\partial x_i}{\partial m_i} + Q_\theta}.$$

Hence, the condition for instability can be rewritten as

$$-\frac{Q_{x_i} \frac{\partial x_i}{\partial m_i}}{Q_\theta} > 1 \quad \text{or} \quad \left| \frac{Q_{x_i} \frac{\partial x_i}{\partial m_i}}{Q_{x_i} \frac{\partial x_i}{\partial m_i} + Q_\theta} \right| > 1. \quad (21)$$

It is obvious that this condition requires Q_θ and $Q_{x_i} \frac{\partial x_i}{\partial m_i}$ to have different signs, as claimed above.

3.5 Convergence under Double Misspecification

So far we have seen that one's unawareness about the opponent's misspecification can influence a learning dynamic and cause non-convergence to an interior steady state in some economic examples. However, this does not imply that one's unawareness always cause non-convergence, and indeed, there are many cases in which the beliefs *do* converge to an interior steady state under double misspecification.

For example, consider the team production problem discussed in the last subsection, but assume now that the output function (20) is replaced with

$$y = a + (1 - \theta)(x_1 + x_2) + \varepsilon. \quad (22)$$

²⁴ The formal derivation is as follows. Note that $\theta_i(m_i)$ is a solution to $Q(x_i(m_i), x_{-i}, \theta^*, a) = Q(x_i(m_i), \hat{x}_{-i}(m_i), \theta_i, A)$. Let Q denote the left-hand side (the true mean) and \hat{Q} denote the right-hand side (the subjective mean). Then by the implicit function theorem, we have

$$\frac{\partial \theta_i}{\partial m_i} = -\frac{\hat{Q}_{x_i} \frac{\partial x_i}{\partial m_i} + \hat{Q}_{x_{-i}} \frac{\partial \hat{x}_{-i}}{\partial m_i} - Q_{x_i} \frac{\partial x_i}{\partial m_i}}{\hat{Q}_\theta} = -\frac{Q_{x_i} \frac{\partial x_i}{\partial m_i}}{Q_\theta}.$$

Here the second equality follows from the fact that we assume $A_1 = A_2 = a$ (and hence $Q = \hat{Q}$) and symmetry. Similarly, $f_i(\theta_{-i})$ is a solution to $Q(x_i(f_i), x_{-i}(\theta_{-i}), \theta^*, a) = Q(x_i(f_i), \hat{x}_{-i}(f_i), f_i, A)$. With an abuse of notation, let Q denote the left-hand side and \hat{Q} denote the right-hand side. Then

$$f'_i(\theta_{-i}) = \frac{Q_{x_{-i}} \frac{\partial x_{-i}}{\partial \theta_{-i}}}{\hat{Q}_{x_i} \frac{\partial x_i}{\partial m_i} + \hat{Q}_{x_{-i}} \frac{\partial \hat{x}_{-i}}{\partial m_i} + \hat{Q}_\theta - Q_{x_i} \frac{\partial x_i}{\partial m_i}} = \frac{Q_{x_i} \frac{\partial x_i}{\partial m_i}}{Q_{x_i} \frac{\partial x_i}{\partial m_i} + Q_\theta}.$$

Again, the second equality uses $A_1 = A_2 = a$ and symmetry.

This new output function is similar to the previous one in that the output y is increasing in the capability a and the total effort $x_1 + x_2$, and is decreasing in the state θ . However, there is one critical difference: with this new output function, the state θ has a *negative impact* on the marginal productivity (i.e., $\frac{\partial^2 Q}{\partial x_i \partial \theta} < 0$), and hence has a *negative impact* on the effort level (i.e., $\frac{\partial x_i}{\partial m_i} < 0$). Accordingly, Q_θ and $Q_{x_i} \frac{\partial x_i}{\partial m_i}$ have the same sign, which means that the condition for instability (21) is not satisfied.

Figure 5 is the phase portrait of the solution to the ODE (17) for this team production problem, with $A_1 = A_2 = a$, $\theta \in \Theta = [0.3, 0.7]$, $\theta^* = 0.5$, and fixed $\xi_1 = \xi_2$.²⁵ As can be seen, the interior steady state (the origin) is *globally attracting* in that for any initial value, the solution reaches a neighborhood of the steady state in finite time.

From this observation, one may expect that players' beliefs converge to this interior steady state almost surely in this example. The following proposition, which directly follows from a well-known result in the literature of stochastic approximation (e.g., Theorem 6.9 of Benaïm (1999)), confirms that this is indeed the case. That is, players' actions and beliefs converge to the interior steady state almost surely, regardless of the initial prior. Given a vector $x \in \mathbf{R}^4$ and a compact set $A \subset \mathbf{R}^4$, let $d(x, A) = \min_{y \in A} |x - y|$ denote the distance from x to the set A .

Definition 1. A set $A \subset \mathbf{R}^4$ is *attracting* if there is a set W such that $A \subseteq \text{int}W$ and such that for any $\varepsilon > 0$, there is $T > 0$ such that $d((m(t), \xi(t)), A) < \varepsilon$ for any initial value $(m, \xi) \in W$ and for any $t > T$. A set A is *globally attracting* if it is attracting and the stochastic process (m^t, ξ^t) moves within the basin W almost surely.

Proposition 4. Suppose that Assumption (i)-(v) in Proposition 2 hold, that $\liminf_{t \rightarrow \infty} m_i^t > -\infty$ and $\limsup_{t \rightarrow \infty} m_i^t < \infty$ for each i with probability one, and that there are $K > 0$ and $\alpha > 0$ such that (15) and (16) hold for all t and (m^t, ξ^t) . If a set A is globally attracting, then the process approaches this set A almost surely, i.e., the probability of $\lim_{t \rightarrow \infty} d((m^t, \xi^t), A) = 0$ is one regardless of the initial prior. In particular, if A is a singleton, then the process converges to this point almost surely.

²⁵ Here we fix the parameter ξ_i , but the result does not change (i.e., the interior steady state is globally attracting) even when ξ_i changes over time. Also the same is true when the parameter A_2 is perturbed so that there is a small amount of misspecification.

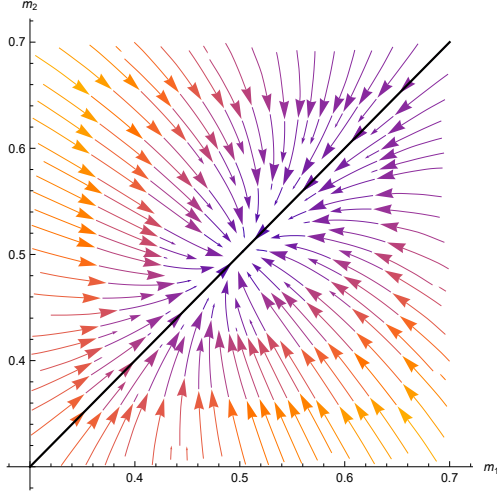

Figure 5: Motion of $m = (m_1, m_2)$

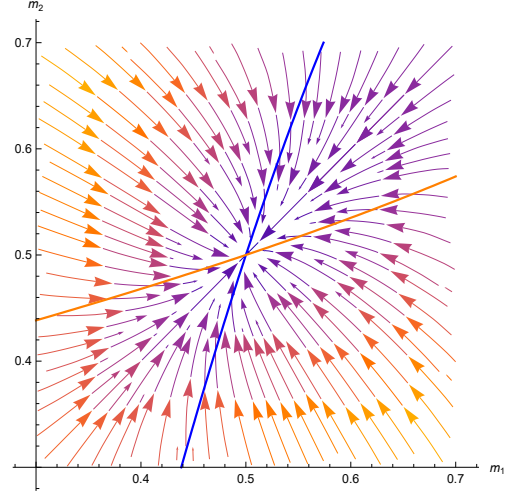

Figure 6: Graphs of f_1 and f_2

Of course, the condition stated in the above proposition is just a sufficient condition for convergence, and there are many cases in which this condition does not hold but nonetheless players' beliefs converge to the steady state. See our companion paper (Murooka and Yamamoto, 2023) for more results and discussions on convergence.

4 Related Literature and Concluding Remarks

There is a rapidly growing literature on Bayesian learning with model misspecification. Nyarko (1991) presents a model in which the agent's action does not converge. Fudenberg, Romanyuk, and Strack (2017) consider a general two-state model and characterize the agent's asymptotic actions and behavior. Ba and Gindin (2023), He (2022), and Heidhues, Kőszegi, and Strack (2018, 2021) study a continuous-state setup, and they show that the agent's action and belief converge to a Berk-Nash equilibrium of Esponda and Pouzo (2016), under some assumptions on payoffs and information structure. Esponda, Pouzo, and Yamamoto (2021) characterize the agent's asymptotic behavior in a general single-agent model. Fudenberg, Lanzani, and Strack (2021) discuss stability of steady states. All these papers look at a single-agent problem or a multi-agent setup in which each player's bias (first-order misspecification) is common knowledge.

Higher-order misspecification has been studied in the literature on social learning (e.g., De-

Marzo, Vayanos, and Zwiebel, 2003; Eyster and Rabin, 2010; Gagnon-Bartsch and Rabin, 2016; Bohren and Hauser, 2021). Most of these papers do not discuss discontinuity of the equilibrium outcome, and indeed, one of the main result of Bohren and Hauser (2021) is that the long-run outcome is robust to a small perturbation of the information structure. An exception is Frick, Iijima, and Ishii (2020), who show that the equilibrium outcome is discontinuous in the information structure in a model of information aggregation. As explained in Introduction, a key assumption is that the agents observe a noise signal about the state only once, which leads to discontinuity of the steady state. In contrast, in our model, the agents have repeated feedbacks about the state, and accordingly the steady states are continuous in the information structure. Nonetheless the equilibrium outcome is discontinuous, because a small misspecification influences the entire learning dynamics and the convergence probability suddenly drops to zero.

In this paper, we have focused on a particular form of higher-order misspecification, where both players are unaware of the opponent having a different view about the world. Of course, there are many other forms of higher-order misspecification which are prevalent in the real world. For example, in some markets, a fraction of consumers is overconfident; cellular phone customers tend to underestimate their usage next month, gym members tend to overestimate how often they will visit the gym, and so on.²⁶ In these cases, misspecification can be on *one side*, i.e., the consumers are misspecified while the companies are rational and understand the consumers' overconfidence. It turns out that this type of *one-sided double misspecification* also leads to the discontinuity of the equilibrium outcome as in our model, i.e., small overconfidence leads to a complete breakdown of correct learning.²⁷ This shows that our model is just an example in which the equilibrium outcome is sensitive to small misspecification. For future research, it may be interesting to study whether other forms of misspecification lead to this kind of sensitivity.

²⁶ See Grubb (2015) for a review of the literature.

²⁷ A rough idea is as follows. Suppose that player 2 is doubly misspecified (i.e., she believes that the true parameter is $A_2 > a$ and she believes that the opponent also believes A_2), while player 1 is fully rational in that she correctly understands the parameter a and player 2's belief hierarchy. When $A_2 = a$, there is no misspecification, so both players learn the true state θ^* . When $A_2 > a$, rational player 1 learns the true state, but player 2 does not. In particular, the evolution of player 2's belief is asymptotically approximated by the belief evolution in the single-agent learning problem appearing in Section 3.4, where player 1's belief is fixed at θ^* . So if the interior steady state of this single-agent learning problem is unstable (Proposition 3 (i) gives the precise condition under which the steady state is indeed unstable), then player 2's belief converges there with zero probability under one-sided double misspecification.

Appendix A: Proof of Proposition 3

Let $(x_i(\theta_i), \hat{x}_{-i}(\theta_i))$ denote the one-shot Nash equilibrium (x_i, \hat{x}_{-i}) given a state θ_i and a parameter A_i . By the assumption, for the steady-state belief $\theta_2 = m_2^*$, $f_1(\theta_2)$ solves $Q(x_1(\theta_1), \hat{x}_2(\theta_1), \theta_1) = Q(x_1(\theta_1), x_2(\theta_2), \theta^*)$. So by the implicit function theorem,

$$\frac{\partial f_1}{\partial \theta_2} = \frac{\frac{\partial Q^*}{\partial x_2} \frac{\partial x_2(\theta_2)}{\partial \theta_2}}{\frac{\partial Q}{\partial x_1} \frac{\partial x_1(\theta_1)}{\partial \theta_1} + \frac{\partial Q}{\partial \hat{x}_2} \frac{\partial \hat{x}_2(\theta_1)}{\partial \theta_1} + \frac{\partial Q}{\partial \theta_1} - \frac{\partial Q^*}{\partial x_1} \frac{\partial x_1(\theta_1)}{\partial \theta_1}},$$

where $Q = Q(x_1(\theta_1), \hat{x}_2(\theta_1), \theta_1)$ and $Q^* = Q(x_1(\theta_1), x_2(\theta_2), \theta^*)$.

On the other hand, given (m_1, m_2) , the KL minimizer $\theta_1(m_1, m_2)$ solves $Q(x_1(m_1), \hat{x}_2(m_1), \theta_1) = Q(x_1(m_1), x_2(m_2), \theta^*)$. So by the implicit function theorem,

$$\frac{\partial \theta_1}{\partial m_1} = - \frac{\frac{\partial Q}{\partial x_1} \frac{\partial x_1(\theta_1)}{\partial \theta_1} + \frac{\partial Q}{\partial \hat{x}_2} \frac{\partial \hat{x}_2(\theta_1)}{\partial \theta_1} - \frac{\partial Q^*}{\partial x_1} \frac{\partial x_1(\theta_1)}{\partial \theta_1}}{\frac{\partial Q}{\partial \theta_1}}.$$

Similarly,

$$\frac{\partial \theta_1}{\partial m_2} = \frac{\frac{\partial Q^*}{\partial x_2} \frac{\partial x_2(\theta_2)}{\partial \theta_2}}{\frac{\partial Q}{\partial \theta_1}}.$$

Then simple algebra shows that

$$\frac{\partial f_1}{\partial \theta_2} = \frac{\partial \theta_1}{\partial m_2} \frac{1}{1 - \frac{\partial \theta_1}{\partial m_1}} \quad (23)$$

To interpret this equation, suppose that player 2's belief θ_2 increases. Then her optimal action x_2 changes, which influences player 1's belief (KL minimizer) by $\frac{\partial \theta_1}{\partial m_2}$. Since player 1's belief changes, her optimal action changes, which influences her own belief (KL minimizer) by $\frac{\partial \theta_1}{\partial m_2} \frac{\partial \theta_1}{\partial m_1}$. Then again player 1's optimal action changes, which influences her own belief by $\frac{\partial \theta_1}{\partial m_2} \left(\frac{\partial \theta_1}{\partial m_1}\right)^2$, and so on. The total effect of this process is

$$\frac{\partial \theta_1}{\partial m_2} \left\{ 1 + \frac{\partial \theta_1}{\partial m_1} + \left(\frac{\partial \theta_1}{\partial m_1}\right)^2 + \dots \right\},$$

which equals the right-hand side of the above equation.

Now, recall that the eigenvalues of the matrix J' solves

$$\left(\frac{\partial \theta_1}{\partial m_1} - 1 - \lambda\right) \left(\frac{\partial \theta_2}{\partial m_2} - 1 - \lambda\right) - \frac{\partial \theta_1}{\partial m_2} \frac{\partial \theta_2}{\partial m_1} = 0,$$

which is equivalent to

$$\lambda^2 - \left(\frac{\partial \theta_1}{\partial m_1} + \frac{\partial \theta_2}{\partial m_2} - 2 \right) \lambda + \left(\frac{\partial \theta_1}{\partial m_1} - 1 \right) \left(\frac{\partial \theta_2}{\partial m_2} - 1 \right) - \frac{\partial \theta_1}{\partial m_2} \frac{\partial \theta_2}{\partial m_1} = 0. \quad (24)$$

Part (i): $\frac{\partial \theta_i}{\partial m_i} - 1 > 0$ for each i .

Suppose that $\frac{\partial \theta_i}{\partial m_i} - 1 > 0$ for each i . Then $\frac{\partial \theta_1}{\partial m_1} + \frac{\partial \theta_2}{\partial m_2} - 2 > 0$, Hence if (24) have real solutions, at least one of them must be positive, implying linear instability. If (24) have imaginary solutions, then the real part of these solutions is $\frac{1}{2} \left(\frac{\partial \theta_1}{\partial m_1} + \frac{\partial \theta_2}{\partial m_2} - 2 \right) > 0$, which again implies linear instability.

Part (ii): $\frac{\partial \theta_i}{\partial m_i} - 1 < 0$ for each i .

Assume first that $f'_1 f'_2 > 1$. Plugging (23) into $f'_1 f'_2 > 1$, we have

$$\frac{\partial \theta_1}{\partial m_2} \frac{1}{1 - \frac{\partial \theta_1}{\partial m_1}} \frac{\partial \theta_2}{\partial m_1} \frac{1}{1 - \frac{\partial \theta_2}{\partial m_2}} > 1.$$

Since we assume $\frac{\partial \theta_i}{\partial m_i} - 1 < 0$, this inequality is equivalent to

$$\frac{\partial \theta_1}{\partial m_2} \frac{\partial \theta_2}{\partial m_1} > \left(1 - \frac{\partial \theta_1}{\partial m_1} \right) \left(1 - \frac{\partial \theta_2}{\partial m_2} \right)$$

This implies that the y-intercept of the quadratic curve appearing in (24) is negative, which in turn implies that (24) has one positive solution and one negative solution. Hence the steady state is linearly unstable.

Next, consider the case with $f'_1 f'_2 < 1$. Algebra similar to the one above yields

$$\frac{\partial \theta_1}{\partial m_2} \frac{\partial \theta_2}{\partial m_1} < \left(1 - \frac{\partial \theta_1}{\partial m_1} \right) \left(1 - \frac{\partial \theta_2}{\partial m_2} \right),$$

which means that the y-intercept of the curve appearing in (24) is positive. Since we assume $\frac{\partial \theta_i}{\partial m_i} < 1$, we have $\frac{\partial \theta_1}{\partial m_1} + \frac{\partial \theta_2}{\partial m_2} - 2 < 0$. Hence if (24) have real solutions, they must be negative, implying asymptotic stability. If (24) have imaginary solutions, then the real part of these solutions is $\frac{1}{2} \left(\frac{\partial \theta_1}{\partial m_1} + \frac{\partial \theta_2}{\partial m_2} - 2 \right) < 0$, which again implies asymptotic stability. *Q.E.D.*

References

- Attari, S.Z., M.L. DeKay, C.I. Davidson, and W.B. de Bruin (2010): “Public Perceptions of Energy Consumption and Savings” *Proceedings of the National Academy of Sciences*, 107 (37), 16054-16059.
- Ba, C. and A. Gindin (2023): “A Multi-Agent Model of Misspecified Learning with Overconfidence,” Working Paper.
- Benaïm, M. (1999): “Dynamics of Stochastic Approximation Algorithms,” Séminaire de Probabilités XXXIII, Lecture Notes in Math. 1709, Springer.
- Benaïm, M. and M. Faure (2012): “Stochastic Approximation, Cooperative Dynamics and Supermodular Games,” *Annals of Applied Probability*, 22, 2133-2164.
- Benaïm, M., J. Hofbauer, and S. Sorin (2005): “Stochastic Approximations and Differential Inclusions,” *SIAM Journal on Control and Optimization*, 44, 328-348.
- Billingsley, P. (1999): *Convergence of Probability Measures*, Wiley.
- Bohren, J.A. and D.N. Hauser (2021): “Learning with Heterogeneous Misspecified Models: Characterization and Robustness,” *Econometrica*, 89 (6), 3025-3077.
- Camerer, C. and D. Lovo (1999): “Overconfidence and Excess Entry: An Experimental Approach,” *American Economic Review*, 89 (1), 306-318.
- Chen, Y-C., A. Di Tillio, E. Faingold, and S. Xiong (2017): “Characterizing the Strategic Impact of Misspecified Beliefs,” *Review of Economic Studies*, 84, 1424-1471.
- Daniel, K. and D. Hirshleifer (2015): “Overconfident Investors, Predictable Returns, and Excessive Trading,” *Journal of Economic Perspectives*, 29 (4), 61-88.
- Dechezleprêtre, A., A. Fabre, T. Kruse, B. Planterose, A.S. Chico, and S. Stantcheva (2022): “Fighting Climate Change: International Attitudes Toward Climate Policies,” Working Paper.
- Deimling, K. (1992): *Multivalued Differential Equations*, Walter de Gruyter.
- DeMarzo, P.M., D. Vayanos, and J. Zwiebel (2015): “Persuasion Bias, Social Influence, and Unidimensional Opinions,” *Quarterly Journal of Economics*, 118 (3), 909-968.
- Dudley, R. (1966): “Convergence of Baire Measures,” *Studia Mathematica*, 27, 251-268.
- Esponda, I. and D. Pouzo (2016): “Berk-Nash Equilibrium: A Framework for Modeling Agents with Misspecified Models,” *Econometrica*, 84, 1093-1130.
- Esponda, I., D. Pouzo, and Y. Yamamoto (2021): “Asymptotic Behavior of Bayesian Learners with Misspecified Models,” *Journal of Economic Theory*, 195, 105260.

- Esponda, I., D. Pouzo, and Y. Yamamoto (2022): “Corrigendum to “Asymptotic Behavior of Bayesian Learners with Misspecified Models” [J. Econ. Theory 195 (2021) 105260],” *Journal of Economic Theory*, 204, 105513.
- Eyster, E. (2019): “Errors in Strategic Reasoning,” In D.B. Bernheim, S. DellaVigna & D. Laibson, (Eds.), *Handbook of Behavioral Economics: Foundations and Applications 2*, 187-259, North Holland.
- Eyster, E. and M. Rabin (2010): “Naïve Herding in Rich-Information Settings,” *American Economic Journal: Microeconomics*, 2 (4), 221-43.
- Frick, M., R. Iijima, and Y. Ishii (2020): “Misinterpreting Others and the Fragility of Social Learning,” *Econometrica*, 88, 2281-2328.
- Fudenberg, D. and D. Kreps (1993): “Learning Mixed Equilibria,” *Games and Economic Behavior*, 5, 320-367.
- Fudenberg, D., G. Lanzani, and P. Strack (2021): “Limit Points of Endogenous Misspecified Learning,” *Econometrica*, 89, 1065-1098.
- Fudenberg, D., G. Romanyuk, and P. Strack (2017): “Active Learning with a Misspecified Prior,” *Theoretical Economics*, 12, 1155-1189.
- Gagnon-Bartsch, T. and M. Rabin (2016): “Naive Social Learning, Mislearning, and Unlearning,” Working Paper.
- Grubb, M. (2015): “Overconfident Consumers in the Marketplace,” *Journal of Economic Perspectives*, 29 (4), 9-36.
- He, K. (2022): “Mislearning from Censored Data: The Gambler’s Fallacy and Other Correlational Mistakes in Optimal-Stopping Problems,” *Theoretical Economics*, 17, 1269-1312.
- Heidhues, P., B. Kőszegi, and P. Strack (2018): “Unrealistic Expectations and Misguided Learning,” *Econometrica*, 86, 1159-1214.
- Heidhues, P., B. Kőszegi, and P. Strack (2021): “Convergence in Models of Misspecified Learning,” *Theoretical Economics*, 16, 73-99.
- Hofbauer, J., J. Oechssler, and F. Riedel (2009): “Brown-von Neumann-Nash Dynamics: the Continuous Strategy Case,” *Games and Economic Behavior*, 65, 406-429.
- Kushner, H.J. and G.G. Yin (2003): *Stochastic Approximation and Recursive Algorithms and Applications*, Springer.
- Ludwig, S. and J. Nafziger (2011): “Beliefs about Overconfidence,” *Theory and Decision*, 70, 475-500.
- Malmendier, U. and G. Tate (2005): “CEO Overconfidence and Corporate Investment,” *Journal of Finance*, 60 (6), 2661-2700.

- Malmendier, U. and G. Tate (2008): “Who Makes Acquisitions? CEO Overconfidence and the Market’s Reaction,” *Journal of Financial Economics*, 89 (1), 20-43.
- Malmendier, U. and G. Tate (2015): “Behavioral CEOs: The Role of Managerial Overconfidence,” *Journal of Economic Perspectives*, 29 (4), 37-60.
- McGee, D. (2023): “Stereotypes and Strategic Discrimination,” Working Paper.
- Murooka, T. and Y. Yamamoto (2023): “Convergence and Steady-State Analysis under Higher-Order Misspecification,” mimeo. <https://drive.google.com/file/d/1tUNo98mLPCoabLbJctVKfJJIC8QL8IE/view>
- Nyarko, Y. (1991): “Learning in Mis-Specified Models and the Possibility of Cycles,” *Journal of Economic Theory*, 55, 416-427.
- Pemantle, R. (1990): “Nonconvergence to Unstable Points in Urn Models and Stochastic Approximations,” *Annals of Probability*, 18, 698-712.
- Perkins, S. and D.S. Leslie (2014): “Stochastic Fictitious Play with Continuous Action Sets,” *Journal of Economic Theory*, 152, 179-213.
- Van Boven, L., D. Dunning, and G. Loewenstein (2000): “Egocentric empathy gaps between owners and buyers: Misperceptions of the endowment effect,” *Journal of Personality and Social Psychology*, 79 (1), 66-76.
- Varian, H.R. (1992): *Microeconomic Analysis* (3rd ed.), Norton.

Online Appendix

B Non-Convergence Theorem for a General Stochastic Process

In this appendix, we will extend the non-convergence theorem of Pemantle (1990) and show that the same non-convergence result holds in a more general environment which includes our model as a special case. This result is used in the proofs of the various non-convergence results in the main text.

Consider a stochastic difference equation

$$v(t+1) - v(t) = \frac{1}{t+1} (F(v(t)) + b(t, v(t))\varepsilon) \quad (25)$$

where $v(t) \in \mathbf{R}^n$, $F : \mathbf{R}^n \rightarrow \mathbf{R}^n$, $b(t, v(t)) \in \mathbf{R}^n$, and $\varepsilon \sim N(0, 1)$. We assume that F is Lipschitz-continuous, and that there is \bar{b} such that $|b_i(t, v)| < \bar{b}$ for all i, t , and $v \in \mathbf{R}^n$, where $b_i(t, v)$ is the i th component of the vector $b(t, v)$. This second assumption essentially means that the variance of the noise is bounded.

A stochastic process $\{v(t)\}_{t=1}^{\infty}$ is a *perturbed solution to (25)* if it solves

$$v(t+1) - v(t) = \frac{1}{t+1} (\tilde{F}(t, v(t)) + b(t, v(t))\varepsilon)$$

for some \tilde{F} such that there is $K > 0$ and $\alpha > 0$ such that for all t and v ,

$$|F(v) - \tilde{F}(t, v)| < \frac{K}{t^\alpha}.$$

It follows from the theory of stochastic approximation (e.g, Theorem 2.1 of Kushner and Yin (2003)) that if a stochastic process $\{v(t)\}$ is a perturbed solution to (25), and if this process $\{v(t)\}_{t=1}^{\infty}$ is bounded with probability one, i.e.,

$$\Pr \left(\limsup_{t \rightarrow \infty} |v(t)| < \infty \right) = 1.$$

then the asymptotic motion $\{v(t)\}$ is approximated by the ODE

$$\frac{dw(t)}{dt} = F(v(t)). \quad (26)$$

A point $p \in \mathbf{R}^n$ is a *steady state* of the ODE if $F(p) = 0$. A steady state p is *linearly unstable* if the Jacobian of F at p has at least one eigenvalue with a positive real part. Pemantle (1990)

shows that there is zero probability of the stochastic process converging to linearly unstable steady states, i.e., $\Pr(\lim_{t \rightarrow \infty} v(t) = p) = 0$ for any linearly unstable steady state p , under a few technical assumptions. His result does not apply to our setup, because (i) we consider a perturbed solution to (25), (ii) the noise term ε has an unbounded support, and (iii) the noise term ε is common for all variables, F_1, \dots, F_n . An important consequence of the second assumption (ii) is that the step size $v(t+1) - v(t)$ is bounded by $\frac{\tilde{c}}{t+1}$, which is frequently used in Pemantle's proof.

The following proposition shows that these features are not essential and Pemantle's result still holds in our model.

Proposition 5. *Let p be a linearly unstable steady state of the ODE (26). Let H be the affine space spanned by the eigenvectors associated with the eigenvalues with negative real parts, and let H^* be the set of all unit vectors orthogonal to H . Assume that there is $\kappa > 0$, $t^* > 0$, and a neighborhood U of p such that $|b(t, v) \cdot h| \geq \kappa$ for all $h \in H^*$, $t \geq t^*$, and $v \in U$. If there is K and a neighborhood U' of p such that $|F(v) - \tilde{F}(t, v)| < \frac{K}{t}$ for all $v \in U'$ and t , then $\Pr(\lim_{t \rightarrow \infty} v(t) = p) = 0$.*

C Proofs

C.1 Proof of Proposition 1

For part (i), note that when $A_2 = a(= A_1)$, players have the same view about the world and hence have the same posterior belief $\mu_1^t = \mu_2^t$ every period. Hence the problem reduces to the classical individual learning problem with no misspecification, and the result follows from a standard argument (a version of the law of large numbers).

So in what follows, we will prove part (ii) of the proposition. We will first show that the process converges to the interior steady state with zero probability. Then we will show that the process converges to the boundary steady states.

Part 1: Non-convergence to p First, we will show that there is zero probability of the process converging to the interior steady state p . For this, it suffices to show that assumptions (i)-(vii) stated in Proposition 2 hold and that the interior steady state p is linearly unstable.

From the first-order condition, a Nash equilibrium (x_i, \hat{x}_{-i}) given θ_i is unique and $x_i = \hat{x}_{-i} = 1 - \theta_i$. Hence assumption (i) holds.

Assumptions (ii)-(v) are obviously satisfied. To check assumptions (vi), let $\tilde{m}(m, \xi)$ denote the mean of the truncated normal $\tilde{N}(m, \frac{1}{\xi})$. Since each player's payoffs are linear in θ , given a posterior belief $\mu_i^t = \tilde{N}(m_i^t, \frac{1}{(t-1)\xi_i^t})$, player i and hypothetical player j chooses a Nash equilibrium for a state $\theta = \tilde{m}(m_i^t, (t-1)\xi_i^t)$. So from the Lipschitz-continuity of θ_i and I_i , assumption (vi) follows from part (iv) of the next lemma. (Parts (i)-(iii) of this lemma are not used here, but we will use them when we prove convergence to the boundary steady states.)

Lemma 1. *There is $k > 0$ and $\bar{t} > 0$ such that for all $t > \bar{t}$ and all ξ which arises on the equilibrium path,*

$$(i) \quad |\tilde{m}(m, t\xi) - m| < \frac{k}{\sqrt{t}} \text{ for all } m \in \Theta,$$

$$(ii) \quad |\tilde{m}(m, t\xi) - \underline{\theta}| < \frac{k}{\sqrt{t}} \text{ for all } m < \underline{\theta},$$

$$(iii) \quad |\tilde{m}(m, t\xi) - \bar{\theta}| < \frac{k}{\sqrt{t}} \text{ for all } m > \bar{\theta}.$$

Also, for any interior point $\theta^* \in \Theta$, there is a neighborhood U of θ^* , $k > 0$, and $\bar{t}' > 0$ such that for all $t > \bar{t}'$ and $m \in U$,

$$(iv) \quad |\tilde{m}(m, t\xi) - m| < \frac{k}{t}.$$

Proof. Let ξ be the minimum of $I_i(x_i, \hat{x}_{-i})$ over all actions (x_i, \hat{x}_{-i}) which can be chosen on the equilibrium path, and we will show that (i)-(iv) hold for this particular ξ . Then it is straightforward to see that (i)-(iv) holds for all other ξ .

Let ϕ denote the pdf of the standard normal $N(0, 1)$, and let Φ denote its cdf. Pick some truncated normal distribution $\tilde{N}(m, \frac{1}{t\xi})$. It is well-known that the mean of this truncated normal distribution is

$$\tilde{m}(m, t\xi) = m + \frac{1}{\sqrt{t\xi}} \cdot \frac{\phi(\sqrt{t\xi}(\bar{\theta} - m)) - \phi(\sqrt{t\xi}(\underline{\theta} - m))}{\Phi(\sqrt{t\xi}(\bar{\theta} - m)) - \Phi(\sqrt{t\xi}(\underline{\theta} - m))} \quad (27)$$

Since $\phi(x) = \frac{1}{\sqrt{2\pi}} \exp(-0.5x^2) \leq \frac{1}{\sqrt{2\pi}}$,

$$|\phi(\sqrt{t\xi}(\bar{\theta} - m)) - \phi(\sqrt{t\xi}(\underline{\theta} - m))| < \frac{1}{\sqrt{2\pi}}.$$

Also there is $\bar{t} > 0$ such that for all $m \in \Theta$ and $t > \bar{t}$,

$$\Phi(\sqrt{t\xi}(\bar{\theta} - m)) - \Phi(\sqrt{t\xi}(\underline{\theta} - m)) > \frac{1}{3}. \quad (28)$$

Plugging these into (27), we have

$$|\tilde{m}(m, t\xi) - m| < \frac{1}{\sqrt{t\xi}} \cdot \frac{3}{\sqrt{2\pi}}$$

for all $m \in \Theta$ and $t > \bar{t}$, which implies (i).

Next, we will prove (iv). Note that

$$|\phi(\sqrt{t\xi}(\bar{\theta} - m)) - \phi(\sqrt{t\xi}(\underline{\theta} - m))| = \frac{1}{\sqrt{2\pi}} \left| \left(\frac{1}{(\sqrt{e})^{(\bar{\theta}-m)^2}} \right)^{t\xi} - \left(\frac{1}{(\sqrt{e})^{(\underline{\theta}-m)^2}} \right)^{t\xi} \right|.$$

Pick $\theta^* \in (\underline{\theta}, \bar{\theta})$. Then there is a neighborhood U of θ^* such that we have $\frac{1}{(\sqrt{e})^{(\bar{\theta}-m)^2}} < 1$ and $\frac{1}{(\sqrt{e})^{(\underline{\theta}-m)^2}} < 1$ for all $m \in U$. Then there is \bar{t}' such that

$$|\phi(\sqrt{t\xi}(\bar{\theta} - m)) - \phi(\sqrt{t\xi}(\underline{\theta} - m))| < \frac{1}{t}$$

for all $m \in U$ and $t > \bar{t}'$. Plugging this and (28) into (27), we have (iv).

Finally, we will prove (ii) and (iii). Let $\tilde{\phi}(m, \frac{1}{\xi})$ denote the pdf of the truncated normal $\tilde{N}(m, \frac{1}{\xi})$.

Then for any $x > 0$ and $m < \underline{\theta}$,

$$\frac{\tilde{\phi}\left(\underline{\theta}, \frac{1}{\xi}\right)[\underline{\theta} + x]}{\tilde{\phi}\left(\underline{\theta}, \frac{1}{\xi}\right)[\underline{\theta}]} = \frac{\phi(\sqrt{\xi}x)}{\phi(0)} > \frac{\phi(\sqrt{\xi}(\underline{\theta} - m + x))}{\phi(\sqrt{\xi}(\underline{\theta} - m))} = \frac{\tilde{\phi}\left(m, \frac{1}{\xi}\right)[\underline{\theta} + x]}{\tilde{\phi}\left(m, \frac{1}{\xi}\right)[\underline{\theta}]}.$$

This means that the truncated normal $\tilde{N}(\underline{\theta}, \frac{1}{\xi})$ first-order stochastically dominates $\tilde{N}(m, \frac{1}{\xi})$ for all $m < \underline{\theta}$. Hence

$$\underline{\theta} < \tilde{m}(m, \xi) < \tilde{m}(\underline{\theta}, \xi)$$

for all $m < \underline{\theta}$. Together with part (i) of the lemma, we obtain (ii). The proof of (iii) is similar and hence omitted. Q.E.D.

Next, we will check (vii). We need to show that $(\frac{1}{\sqrt{I_1}}, \frac{1}{\sqrt{I_2}})$ is not an eigenvector of J' , i.e.,

$$\begin{pmatrix} \frac{\partial \theta_1}{\partial m_1} - 1 & \frac{\partial \theta_1}{\partial m_2} \\ \frac{\partial \theta_2}{\partial m_1} & \frac{\partial \theta_2}{\partial m_2} - 1 \end{pmatrix} \begin{pmatrix} \frac{1}{\sqrt{I_1(p)}} \\ \frac{1}{\sqrt{I_2(p)}} \end{pmatrix} \neq \lambda \cdot \begin{pmatrix} \frac{1}{\sqrt{I_1(p)}} \\ \frac{1}{\sqrt{I_2(p)}} \end{pmatrix}$$

for any $\lambda \in \mathbf{R}$. This is equivalent to show that

$$\left(\frac{\partial \theta_1}{\partial m_1} - 1 \right) + \frac{\partial \theta_1}{\partial m_2} \frac{\sqrt{I_1(p)}}{\sqrt{I_2(p)}} \neq \frac{\partial \theta_2}{\partial m_1} \frac{\sqrt{I_2(p)}}{\sqrt{I_1(p)}} + \left(\frac{\partial \theta_2}{\partial m_2} - 1 \right). \quad (29)$$

Note that $\theta_i(m)$ solves $Q(x_i(m_i), \hat{x}_{-i}(m_i), A_i, \theta_i) = Q(x_i(m_i), x_{-i}(m_{-i}), a, \theta^*)$. By the implicit function theorem, we have

$$\begin{aligned} \frac{\partial \theta_i}{\partial m_i} &= - \frac{\frac{\partial Q_i}{\partial x_i} \frac{\partial x_i}{\partial m_i} + \frac{\partial Q_i}{\partial \hat{x}_{-i}} \frac{\partial \hat{x}_{-i}}{\partial m_i} - \frac{\partial Q^*}{\partial x_i} \frac{\partial x_i}{\partial m_i}}{\frac{\partial Q_i}{\partial \theta_i}} = - \frac{2 \frac{\partial Q_i}{\partial x_i} \frac{\partial x_i}{\partial m_i} - \frac{\partial Q^*}{\partial x_i} \frac{\partial x_i}{\partial m_i}}{\sqrt{I_i}}, \\ \frac{\partial \theta_i}{\partial m_j} &= \frac{\frac{\partial Q^*}{\partial x_j} \frac{\partial x_j}{\partial m_j}}{\frac{\partial Q_i}{\partial \theta_i}} = \frac{\frac{\partial Q^*}{\partial x_j} \frac{\partial x_j}{\partial m_j}}{\sqrt{I_i}}, \end{aligned}$$

where $Q_i = Q(x_i(m_i), \hat{x}_{-i}(m_i), A_i, \theta_i)$ denotes player i 's subjective expectation of the output and $Q^* = Q(x_i(m_i), x_{-i}(m_{-i}), a, \theta^*)$ is the true mean. Combining these two equalities, we have

$$\frac{\partial \theta_i}{\partial m_i} - 1 + \frac{\sqrt{I_i}}{\sqrt{I_j}} \frac{\partial \theta_i}{\partial m_j} = \frac{-2 \frac{\partial Q_i}{\partial x_i} \frac{\partial x_i}{\partial m_i} + \frac{\partial Q^*}{\partial x_i} \frac{\partial x_i}{\partial m_i}}{\sqrt{I_i}} - 1 + \frac{\frac{\partial Q^*}{\partial x_{-i}} \frac{\partial x_{-i}}{\partial m_{-i}}}{\sqrt{I_{-i}}}.$$

Using this equation, (29) can be rewritten as

$$\frac{-2 \frac{\partial Q_1}{\partial x_1} \frac{\partial x_1}{\partial m_1}}{\sqrt{I_1}} \neq \frac{-2 \frac{\partial Q_2}{\partial x_2} \frac{\partial x_2}{\partial m_2}}{\sqrt{I_2}},$$

which is further simplified to

$$-\frac{m_1}{1-m_1} \neq -\frac{m_2}{1-m_2}$$

because $x_i = \hat{x}_{-1} = 1 - \theta_i$. This inequality indeed holds (and hence assumption (vii) is satisfied), because $\frac{m_i}{1-m_i}$ is increasing in m_i on the set Θ , and the consistency condition implies that $m_1^* \neq m_2^*$ in any interior steady state with $A_2 \neq A_1 = a$.

To conclude the proof, we will show that the interior steady state p is linearly unstable. From Proposition 3 (i), it suffices to show that $\frac{\partial \theta_i(m)}{\partial m_i} > 1$ for each i . For the special case with $A_1 = A_2 = a$, we have $\frac{\partial \theta_i(m)}{\partial m_i} = 2$. Then by the continuity, for any A_2 close to a , we still have $\frac{\partial \theta_i(m)}{\partial m_i} > 1$.

Part 2: Convergence to boundary beliefs We will first show that the stochastic process (m^t, ξ^t) is bounded with probability one. Recall that regardless of the parameter A_i , a Nash equilibrium

given a state θ_i is $x_i = \hat{x}_{-i} = 1 - \theta_i$. Hence on the equilibrium path, each player's production is at least $\underline{x} = 1 - \bar{\theta}$ but does not exceed $\bar{x} = 1 - \underline{\theta}$.

Let \underline{m}_i be such that

$$A_i - \underline{m}_i(\bar{x} + \bar{x}) = a - \theta^*(\bar{x} + \underline{x}).$$

In words, $\underline{m}_i \in \mathbf{R}$ denotes a state with which player i 's subjective expectation about the output matches the true mean, when player i thinks that the opponent chooses the maximal effort \bar{x} but in reality she chooses the minimal effort \underline{x} . Note that this \underline{m}_i is the minimum of $\theta_i(m)$ over all m , and that \underline{m}_i need not be in the state space Θ . Similarly, let \bar{m}_i be such that

$$A_i - \bar{m}_i(\underline{x} + \underline{x}) = a - \theta^*(\underline{x} + \bar{x}).$$

This is a state with which player i 's subjective expectation about the output matches the true mean, when player i thinks that the opponent chooses the minimal effort \underline{x} but in reality she chooses the maximal effort \bar{x} (which yields the most optimistic belief \bar{m}_i). Note that this \bar{m}_i is the maximum of $\theta_i(m)$ over all m .

The following lemma shows that almost surely, m_i^t is in a neighborhood of $[\underline{m}_i, \bar{m}_i]$ after a long time. This immediately implies that the process (m^t, ξ^t) is bounded almost surely; indeed, $I_i(x^\tau)$ has the minimal value $\underline{I} = I_i(\bar{x}, \bar{x})$ and the maximal value $\bar{I} = I_i(\underline{x}, \underline{x})$, so it is obvious that ξ_i^t is always in the bounded interval $[\underline{I}, \bar{I}]$.

Lemma 2. *Given any A_2 , almost surely, $\underline{m}_i \leq \liminf_{t \rightarrow \infty} m_i^t \leq \limsup_{t \rightarrow \infty} m_i^t \leq \bar{m}_i$ for each i .*

From Lemma 1, it is obvious that there is $K > 0$ such that (15) and (16) hold for $\alpha = 0.5$. Then since the process is bounded with probability one, Theorem 2.1 of Kushner and Yin (2003) implies the following lemma: Given a realized infinite-horizon outcome $(m^t, \xi^t)_{t=1}^\infty$, define the *continuous-time interpolation* as a mapping $\mathbf{w} : [0, \infty) \rightarrow \mathbf{R}^4$ such that

$$\mathbf{w}[\tau_t + s] = (m^t, \xi^t) + \frac{\tau}{\tau_{t+1} - \tau_t} ((m^{t+1}, \xi^{t+1}) - (m^t, \xi^t))$$

for all $t = 0, 1, \dots$ and $\tau \in [0, \frac{1}{t+1})$. This \mathbf{w} is an *asymptotic pseudotrajectory* of the ODE if for any $T > 0$,

$$\lim_{t \rightarrow \infty} \sup_{\tau \in [0, T]} |\mathbf{w}(t + \tau) - s(\mathbf{w}(t))[\tau]| = 0 \quad (30)$$

where $s(m, \xi) : \mathbf{R}_+ \rightarrow \mathbf{R}^4$ is a solution to the ODE (17) and (18) given the initial value (m, ξ) .

Lemma 3. *With probability one, \mathbf{w} is an asymptotic pseudotrajectory of the ODE (17) and (18).*

This lemma implies that after a long time, the path \mathbf{w} of the stochastic process is approximated by the solution s to the ODE (17) and (18). So in order to know the long-run outcome of the stochastic process, it suffices to investigate the ODE.

The next lemma characterizes the behavior of the solution to the ODE when player 2's overconfidence is small.

Lemma 4. *Pick a arbitrarily. There is $\bar{A} > a$ such that for any $A_2 \in [a, \bar{A})$ and i , there are values θ'_{-i} and θ''_{-i} with $\underline{\theta} < \theta'_{-i} < \theta''_{-i} < \bar{\theta}$ and differentiable functions $f_i : [\theta'_{-i}, \theta''_{-i}] \rightarrow \Theta$, $\tilde{f}_i : [\underline{\theta}, \theta''_{-i}] \rightarrow [\bar{\theta}, \bar{m}_i]$, and $\hat{f}_i : [\theta'_{-i}, \bar{\theta}] \rightarrow [\underline{m}_i, \underline{\theta}]$ such that the following properties hold:*

- (i) $f'_i(m_{-i}) > 1$ for all m_{-i} , $f_i(\theta'_{-i}) = \underline{\theta}$, $f_i(\theta''_{-i}) = \bar{\theta}$, $\tilde{f}'_i(m_{-i}) < 0$ for all m_{-i} , $\tilde{f}_i(\underline{\theta}) = \bar{m}_i$, $\tilde{f}_i(\theta''_{-i}) = \bar{\theta}$, $\hat{f}'_i(m_{-i}) < 0$ for all m_{-i} , $\hat{f}_i(\theta'_{-i}) = \underline{\theta}$, $\hat{f}_i(\bar{\theta}) = \underline{m}_i$,
- (ii) For any $m_{-i} < \underline{\theta}$, $\theta_i(m) - m_i$ is positive if $m_i < \bar{m}_i$, is zero if $m_i = \bar{m}_i$, and is negative if $m_i > \bar{m}_i$.
- (iii) For any $m_{-i} \in [\underline{\theta}, \theta'_{-i})$, $\theta_i(m) - m_i$ is positive if $m_i < \tilde{f}_i(m_{-i})$, is zero if $m_i = \tilde{f}_i(m_{-i})$, and is negative if $m_i > \tilde{f}_i(m_{-i})$,
- (iv) For any $m_{-i} \in [\theta'_{-i}, \theta''_{-i}]$, $\theta_i(m) - m_i$ is positive if $m_i < \hat{f}_i(m_{-i})$, is zero if $m_i = \hat{f}_i(m_{-i})$, is negative if $m_i \in (\hat{f}_i(m_{-i}), f_i(m_{-i}))$, is zero if $m_i = f_i(m_{-i})$, is positive if $m_i \in (f_i(m_{-i}), \tilde{f}_i(m_{-i}))$, is zero if $m_i = \tilde{f}_i(m_{-i})$, and is negative if $m_i > \tilde{f}_i(m_{-i})$.
- v) For any $m_{-i} \in (\theta''_{-i}, \bar{\theta}]$, $\theta_i(m) - m_i$ is positive if $m_i < \hat{f}_i(m_{-i})$, is zero if $m_i = \hat{f}_i(m_{-i})$, and is negative if $m_i > \hat{f}_i(m_{-i})$.
- (vi) For any $m_{-i} > \bar{\theta}$, $\theta_i(m) - m_i$ is positive if $m_i < \underline{m}_i$, is zero if $m_i = \underline{m}_i$, and is negative if $m_i > \underline{m}_i$.

Proof. We will first explain how to choose θ'_{-i} , θ''_{-i} , f_i , \tilde{f}_i , and \hat{f}_i . Let θ'_{-i} be a state θ which solves

$$A_i - \underline{\theta}(x_i(\underline{\theta}) + x_{-i}(\underline{\theta})) = a - \theta^*(x_i(\underline{\theta}) + x_{-i}(\underline{\theta})).$$

When $A_i = a$, the right-hand side $(a - \theta^*(2 - \underline{\theta} - \theta))$ is less than the left-hand side $(a - \underline{\theta}(2 - 2\underline{\theta}))$ at $\theta = \underline{\theta}$, and is greater than that at $\theta = \theta^*$. Also the right-hand side is increasing in θ . Hence θ'_{-i} which solves the equality above is unique and $\underline{\theta} < \theta'_{-i} < \theta^*$. Then by the continuity, the same result holds as long as A_2 is close to a .

Similarly, let θ''_{-i} be a state θ which solves

$$A_i - \bar{\theta}(x_i(\bar{\theta}) + x_{-i}(\bar{\theta})) = a - \theta^*(x_i(\bar{\theta}) + x_{-i}(\theta)).$$

Then again, for A_i close to a , θ''_{-i} is uniquely determined and $\theta^* < \theta''_{-i} < \bar{\theta}$. Hence we have $\underline{\theta} < \theta'_{-i} < \theta''_{-i} < \bar{\theta}$ as stated in the lemma.

Then for each $m_{-i} \in [\underline{\theta}, \theta''_{-i}]$, define $\tilde{f}_i(m_{-i})$ as a value m_i which solves

$$A_i - m_i(x_i(\bar{\theta}) + x_{-i}(\bar{\theta})) = a - \theta^*(x_i(\bar{\theta}) + x_{-i}(m_{-i})),$$

i.e., with this belief m_i , player i 's subjective expectation about the output matches the true mean when she believes that the Nash equilibrium for $\bar{\theta}$ will be chosen but in reality the opponent chooses the Nash equilibrium action for m_{-i} . Note that the above equation is linear in m_i , and hence indeed has a unique solution. By the definition, $\tilde{f}_i(\underline{\theta}) = \bar{m}_i$ and $\tilde{f}_i(\theta''_{-i}) = \bar{\theta}$. Also by the implicit function theorem, $\tilde{f}_i(m_{-i})$ is decreasing in m_{-i} , as stated in the lemma.

Similarly, for each $m_{-i} \in [\theta'_{-i}, \bar{\theta}]$, define $\hat{f}_i(m_{-i})$ as a value m_i which solves

$$A_i - m_i(x_i(\underline{\theta}) + x_{-i}(\underline{\theta})) = a - \theta^*(x_i(\underline{\theta}) + x_{-i}(m_{-i})).$$

Again this equation is linear in m_i , and hence has a unique solution. Also it is easy to check that $\hat{f}_i(\theta'_{-i}) = \underline{\theta}$, $\hat{f}_i(\bar{\theta}) = \underline{m}_i$, and $\hat{f}_i(m_{-i})$ is decreasing in m_{-i} .

Also for each $m_{-i} \in [\theta'_{-i}, \theta''_{-i}]$, define $f_i(m_{-i})$ as a value $m_i \in \Theta$ which solves

$$A_i - m_i(x_i(m_i) + x_{-i}(m_i)) = a - \theta^*(x_i(m_i) + x_{-i}(m_{-i})).$$

To see that this equation has a solution, let

$$g(m_i, m_{-i}) = A_i - m_i(x_i(m_i) + x_{-i}(m_i)) - a + \theta^*(x_i(m_i) + x_{-i}(m_{-i})).$$

By the definition of θ''_{-i} , $g(\bar{\theta}, \theta''_{-i}) = 0$. Then since g is decreasing in m_{-i} , we have $g(\bar{\theta}, m_{-i}) \geq 0$ for all $m_{-i} \in [\theta'_{-i}, \theta''_{-i}]$. Likewise, since $g(\underline{\theta}, \theta'_{-i}) = 0$, we have $g(\underline{\theta}, m_{-i}) \leq 0$ for all $m_{-i} \in [\theta'_{-i}, \theta''_{-i}]$.

Taken together, given any $m_{-i} \in [\theta'_{-i}, \theta''_{-i}]$, we have $g(\underline{\theta}, m_{-i}) \leq 0 \leq g(\bar{\theta}, m_{-i})$, so there is at least one $m_i \in \Theta$ which solves $g(m_i, m_{-i}) = 0$. Also this solution is unique, because given any $m_{-i} \in [\theta'_{-i}, \theta''_{-i}]$, g is strictly increasing in m_i when $m_i \in \Theta$. (Note that g is a quadratic function of m_i .)

By the definition of θ'_{-i} and θ''_{-i} , we have $f_i(\theta'_{-i}) = \underline{\theta}$ and $f_i(\theta''_{-i}) = \bar{\theta}$. Also, by the implicit function theorem,

$$f'_i(m_{-i}) = -\frac{\frac{\partial g}{\partial m_{-i}}}{\frac{\partial g}{\partial m_i}} = \frac{\theta^*}{-2 + 4m_i - \theta^*}.$$

We have $f'_i(m_{-i}) = 2$ at $m_i = m_{-i} = \theta^* = 0.8$ and $f'_i(m_{-i}) > 1$ for any $m_i, m_{-i} \in \Theta$. So all the properties stated in part (i) holds.

Next, we will prove part (iv). Pick $m_{-i} \in (\theta'_{-i}, \theta''_{-i})$ arbitrarily. By the definition of \hat{f}_i , we have $\theta_i(m) = \hat{f}_i(m_{-i})$ for any $m_i \leq \underline{\theta}$. Hence $\theta_i(m) - m_i$ is positive for $m_i < \hat{f}_i(m_{-i})$, is zero for $m_i = \hat{f}_i(m_{-i})$, and is negative for $m_i \in (\hat{f}_i(m_{-i}), \underline{\theta}]$, as stated in the lemma.

For $m_i \in (\underline{\theta}, f_i(m_{-i}))$, we claim that $\theta_i(m) - m_i$ is negative. Suppose not so that $\theta_i(m) - m_i \geq 0$. If $\theta_i(m) - m_i = 0$, then by the definition of f_i , we must have $m_i = f_i(m_{-i})$, which contradicts with $m_i < f_i(m_{-i})$. If $\theta_i(m) - m_i > 0$, then there must be $m'_i \in (\underline{\theta}, m_i)$ such that $\theta_i(m'_i, m_{-i}) - m'_i = 0$. (This is so because $\theta_i(\underline{\theta}, m_{-i}) - \underline{\theta} < 0$.) But then we must have $m'_i = f_i(m_{-i})$, which is a contradiction. Hence $\theta_i(m) - m_i$ is negative in this case.

By the symmetry, for $m_i > f_i(m_{-i})$, all the properties stated in part (iv) of the lemma are satisfied. Also, by the definition of f_i , we have $\theta_i(m) - m_i = 0$ for $m_i = f_i(m_{-i})$. Hence part (iv) follows.

The proofs of the other parts of the lemma are very similar, and hence omitted. *Q.E.D.*

Figure 7 highlights what is shown in the lemma above. Here the horizontal axis represents m_{-i} and the vertical axis represents m_i . The origin is the interior steady-state belief. The large dotted square is $\times_{i=1,2}[\underline{m}_i, \bar{m}_i]$, and recall that after a long time, (m_1^t, m_2^t) is in a neighborhood of this square almost surely. The small dotted square is the state space $\times_{i=1,2}\Theta$. The thick polygonal line is the set of points at which $\frac{d\theta_i(t)}{dt} = \theta_i(m(t)) - m_i(t) = 0$; the downward-sloping line at the top is the graph of the function $\tilde{f}_i(m_{-i})$ defined in the lemma above, the upward-sloping line in the middle is the graph of f_i , and the downward-sloping line at the bottom is the graph of \hat{f}_i . On the left side of this thick line, $\frac{d\theta_i(t)}{dt} = \theta_i(m(t)) - m_i(t) > 0$, which means that the solution $\theta_i(t)$ to the

ODE increases over time. In contrast, on the right side of the line, $\frac{d\theta_i(t)}{dt} = \theta_i(m(t)) - m_i(t) < 0$, and hence $\theta_i(t)$ decreases over time. See the thick arrows in the figure.

Figure 8 describes how the solution to the ODE behaves when both $m_1(t)$ and $m_2(t)$ change over time. The horizontal axis represents m_1 and the vertical axis represents m_2 . The two thick polygonal lines are the set of points at which $\frac{dm_i(t)}{dt} = 0$. If the current value $m(t)$ is on the polygonal line with $\frac{dm_1(t)}{dt} = 0$, only $m_2(t)$ changes at the next instant, so $m(t)$ moves vertically, as shown by the arrows in the figure. Similarly, if the current value is on the polygonal line with $\frac{dm_2(t)}{dt} = 0$, only $m_1(t)$ changes at the next instant, so $m(t)$ moves horizontally. For all other points, both m_1 and m_2 move simultaneously. We cannot pin down the exact motion of $m(t)$ in this case (hence we have fork arrows in the picture) because it depends on the current value of $\xi(t)$, which is not specified here; in general, when ξ_1 is relatively larger than ξ_2 , m_1 moves faster than m_2 , and hence the arrow becomes flatter.

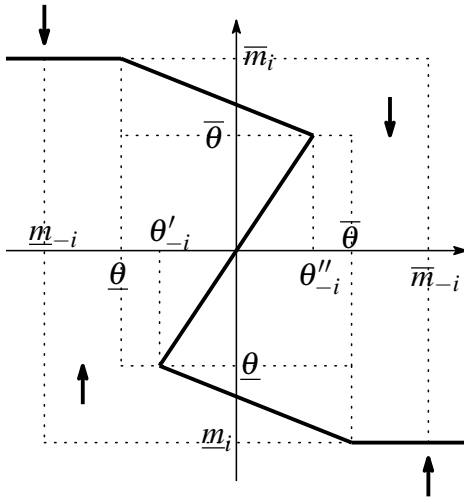

Figure 7: Motion of $m_i(t)$ for Fixed m_{-i}

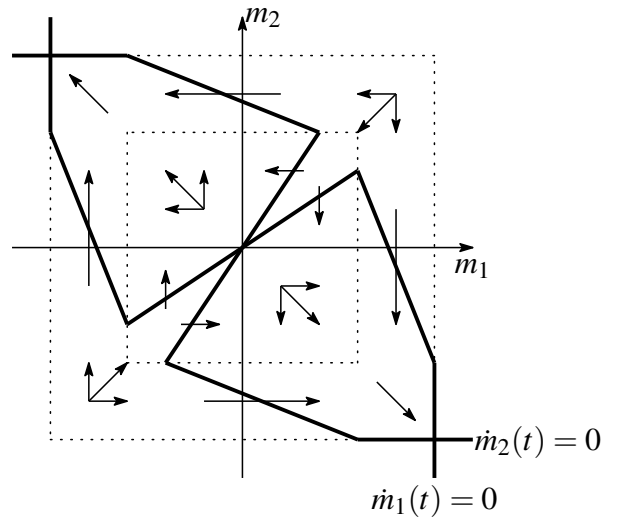

Figure 8: Motion of $m(t)$

As can be seen from the figure, the polygonal lines intersect three times, and these are the steady states of the ODE. That is, the ODE have one interior steady state (the origin) and two boundary steady states ($(\underline{m}_1, \bar{m}_2)$ and $(\bar{m}_1, \underline{m}_2)$). From the figure, it is easy to check that given any initial value (m, ξ) , the solution to the ODE eventually converges to one of these steady states. However, this does not imply that the set of steady states is globally attracting; a problem is that in a neighborhood of the origin (the interior steady state), $(\frac{dm_1(t)}{dt}, \frac{dm_2(t)}{dt})$ is approximately $(0, 0)$,

meaning that the motion of $m(t)$ can be very slow. Accordingly, for some initial value, it takes arbitrarily long time for the solution to reach a neighborhood of the boundary steady state, so we cannot find a uniform bound T appearing in the definition of attracting sets.

Nonetheless, we can show that m^t converge to the boundary steady states. This implies the result we want, as in such a case the actual belief $\tilde{N}(m_i^t, \frac{1}{i\xi_i^t})$ converges to $1_{\underline{\theta}}$ or $1_{\bar{\theta}}$.

Formally, our goal is to prove the following lemma. Let $B = \{(\underline{m}_1, \bar{m}_2, \underline{I}, \bar{I}), (\bar{m}_1, \underline{m}_2, \bar{I}, \underline{I})\}$ denote the set of the boundary steady states. Also, let $M = (\times_{i=1,2} [m_i, \bar{m}_i]) \times [\underline{I}, \bar{I}]^2$.

Lemma 5. *Pick a particular path $\mathbf{w} : \mathbf{R} \rightarrow \mathbf{R}^4$ such that (i) \mathbf{w} is an asymptotic pseudotrajectory of the ODE, (ii) $\lim_{t \rightarrow \infty} d(\mathbf{w}(t), M) = 0$, and (iii) $\lim_{t \rightarrow \infty} \mathbf{w}(t) \neq p$. (Note that these properties hold with probability one, as shown by the earlier lemmas.) Then $\lim_{t \rightarrow \infty} d(\mathbf{w}, B) = 0$.*

Proof. Pick \mathbf{w} as stated. Since $\lim_{t \rightarrow \infty} \mathbf{w}(t) \neq p$, there is $\varepsilon > 0$ such that for any $T > 0$, there is $t > T$ such that $\mathbf{w}(t) \notin (\times_{i=1,2} [m_i^* - \varepsilon, m_i^* + \varepsilon]) \times [\underline{I}, \bar{I}]^2$. Pick such ε .

Now, note that the inverse function f_i^{-1} is increasing and $f_i^{-1}(m_i^*) = m_{-i}^*$. Hence we have $f_i^{-1}(m_i^* - \varepsilon) < f_i^{-1}(m_i^*) < f_i^{-1}(m_i^* + \varepsilon)$. Then there is $\eta > 0$ such that

$$f_i^{-1}(m_i^* - \varepsilon) + 2\eta < f_i^{-1}(m_i^*) < f_i^{-1}(m_i^* + \varepsilon) - 2\eta \quad (31)$$

for all i . Pick such $\eta > 0$. Then let $A \subset \mathbf{R}^4$ be such that

$$A = \{(m, \xi) \in M \mid \min\{m_1 - m_1^*, m_2 - m_2^*\} \leq \eta\} \cap \{(m, \xi) \mid \max\{m_1 - m_1^*, m_2 - m_2^*\} \geq -\eta\}.$$

See Figure 9.

From Figure 8, given any initial value chosen from the ε -neighborhood of M , the solution to the ODE converges to this set A . Also, the solution does not enter a neighborhood of the origin on the way to a neighborhood of A ; this means that the solution reaches a neighborhood of A by some time T , which is independent of the initial value. Thus the set A is attracting, and its basin is the ε -neighborhood of M .

Theorem 6.10 of Benaïm (1999) asserts that if a path \mathbf{w} visits the basin W of an attracting set A infinitely often and if W is compact, then \mathbf{w} converges to the set A . Since we assume that $\lim_{t \rightarrow \infty} d(\mathbf{w}(t), M) = 0$, our path \mathbf{w} indeed visits the ε -neighborhood of M infinitely often (actually \mathbf{w} stays there forever, after a long time). Also ε -neighborhood of M is compact. Hence \mathbf{w} converges

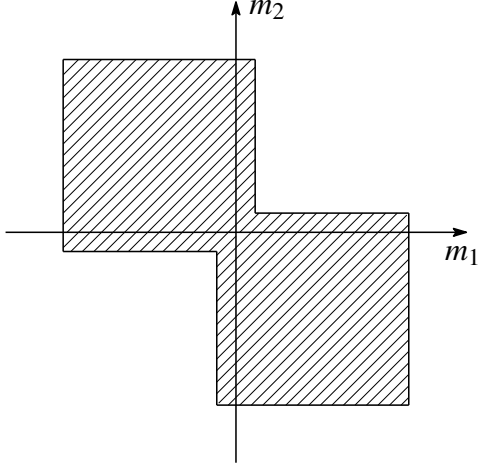

Figure 9: The projection of the set A .

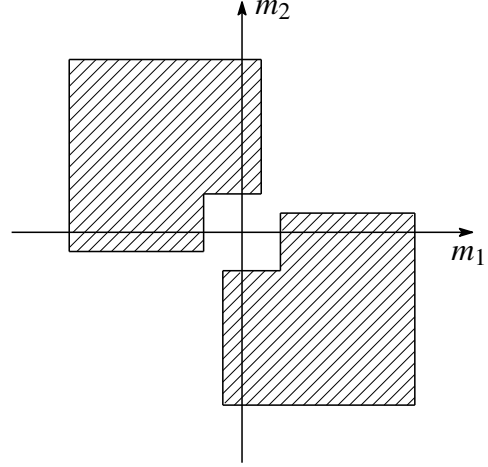

Figure 10: The projection of the set A' .

to the set A , i.e., $\lim_{t \rightarrow \infty} d(\mathbf{w}(t), A) = 0$. This in particular implies that there is $T > 0$ such that for any $t > T$, $\mathbf{w}(t)$ stays in the η -neighborhood of the set A .

At the same time, by the assumption \mathbf{w} leaves the set $(\times_{i=1,2}[m_i^* - \varepsilon, m_i^* + \varepsilon]) \times [L, \bar{I}]^2$ infinitely often. This means that \mathbf{w} visits the set

$$A' = \{(m, \xi) \mid d((m, \xi), A) \leq \eta \text{ and } m \notin \times_{i=1,2}(m_i^* - \varepsilon, m_i^* + \varepsilon)\}$$

infinitely often. See Figure 10.

Note that this set A' is compact and is a basin of the set B of the boundary steady states.²⁸ Hence again from Theorem 6.10 of Benaïm (1999), \mathbf{w} converges to B , as desired. *Q.E.D.*

²⁸ To see that A' is a basin of B , pick any point $(m, \xi) \in A'$. If (m, ξ) is in the fourth quadrant, we have $\frac{dm_1(0)}{dt} > 0$ and $\frac{dm_2(0)}{dt} < 0$, i.e., the solution $m(t)$ to the ODE move toward the south-east direction, and eventually converge to the boundary point $(\bar{m}_1, \underline{m}_2)$. See Figure 8. Also the solution does not enter the ε -neighborhood of the origin, so it reaches a neighborhood of the boundary point by some time T which is independent of the initial value. Next, consider the case in which (m, ξ) is in the first quadrant. In this case we have either $m_1 < m_1^* + 2\eta$ or $m_2 < m_2^* + 2\eta$, and without loss of generality, we will focus on the case with $m_2 < m_2^* + 2\eta$. Then from (31), the point (m, ξ) is below the graph of f_1 (the flatter upward-sloping line in Figure 8). Then again we have $\frac{dm_1(0)}{dt} > 0$ and $\frac{dm_2(0)}{dt} < 0$, so that the solution $m(t)$ moves toward the south-east direction and eventually converges to the boundary point $(\bar{m}_1, \underline{m}_2)$. A similar argument applies when (m, ξ) is in the second or the third quadrant. Hence A' is indeed a basin of B .

C.2 Proof of Proposition 5

Let \mathcal{N} be a neighborhood of p , and choose a function $\eta : \mathcal{N} \rightarrow \mathbf{R}_+$ as in Section 3 of Pemantle (1990), given the ODE (26). Roughly, $\eta(v)$ measures the distance between a point v and (the set of) the paths pointing to the steady state p . For example, any point v with $\eta(v) = 0$ is on such a path, so starting from this point v , a solution to the ODE (26) converges to p .

On the other hand, any point v with $\eta(v) > 0$ is not on such a path. So the solution to the ODE does not converge to p . Indeed, as shown by Proposition 3(v) of Pemantle (1990), we have $D_v(\eta)(F(v)) > 0$ for any v with $\eta(v) > 0$. So a solution to the ODE moves away from the paths converging to p . (Here, the notation for multidimensional derivatives uses $D_v(\eta)$ for the differential of η at a point v .)

Let $S_t = \eta(v(t))$ and $X_t = S_t - S_{t-1}$. Lemma 1 of Pemantle (1990) shows that after every history \mathcal{F}_t , the stochastic process $\{S_k\}$ can exceed $\frac{c^*}{\sqrt{t}}$ (i.e., $v(t)$ leaves a neighborhood of the paths converging to p) at some point in the future with probability at least 0.5. The following lemma shows that the same result holds in our setup. The proof can be found in Appendix C.2.1

Lemma 6. *There is a constant $c^* > 0$ and t^* such that for any $t > t^*$ and \mathcal{F}_t ,*

$$\Pr \left(\sup_{k>t} S_k > \frac{c^*}{\sqrt{t}} \text{ or } v(k) \notin \mathcal{N} \text{ for some } k > t \mid \mathcal{F}_t \right) > 0.5.$$

Lemma 2 of Pemantle (1990) shows that once the process $\{v(t)\}$ leaves a $\frac{c^*}{\sqrt{t}}$ -neighborhood of p as stated in the lemma above, then it fails to return to p with positive probability. The proof can be found in Appendix C.2.2

Lemma 7. *Let $c^* > 0$ be as in Lemma 6. Then there is $a > 0$ such that*

$$\Pr \left(\inf_{k>t} S_k > \frac{c^*}{2\sqrt{t}} \text{ or } v(k) \notin \mathcal{N} \text{ for some } k \geq t \mid \mathcal{F}_t, S_t \geq \frac{c^*}{\sqrt{t}} \right) \geq a.$$

The rest of the proof is exactly the same as the argument in the full paragraph on page 711 of Pemantle (1990): Suppose that $\Pr(v(t) \rightarrow p) > 0$. Then there is some history \mathcal{F}_t after which the probability that $v(M)$ converges to p and never leaves the neighborhood \mathcal{N} is at least $1 - \frac{a}{2}$. However, Lemmas 6 and 7 imply that the probability that $v(M)$ fails to converge to p or leaves \mathcal{N} is at least $\frac{a}{2}$ conditional on any history \mathcal{F}_t . This is a contradiction.

C.2.1 Proof of Lemma 6

Without loss of generality, assume that \mathcal{N} (the domain of the “distance function” η) is a closed ball surrounding p . (This is so because given a neighborhood U of the point p , we can always find a closed ball $\mathcal{N} \subseteq U$ containing p .) Then enlarge the domain of η by letting $\eta(v) = \eta(\arg \max_{\tilde{v} \in \mathcal{N}} d(\tilde{v}, \mathcal{N}))$ for each $v \notin \mathcal{N}$. Here $d(v, \mathcal{N})$ measures the Euclidean distance between v and the ball \mathcal{N} . This function η is well-defined because \mathcal{N} is a closed ball. Since η is Lipschitz in \mathcal{N} , it is so in the entire space \mathbf{R}^n .

Pick a sufficiently large t , and define a stopping time $\tau = \{M \geq t | S_M > \frac{c^*}{\sqrt{t}}\}$. We will show that $\Pr(\tau = \infty | \mathcal{F}_t) < 0.5$.

Step 1: Inequalities (12) and (14) of Pemantle (1990).

In the proof Pemantle (1990), he shows that there is $k_2 > 0$ such that for any $M > t$ with $S_M \leq \frac{c^*}{\sqrt{t}}$,

$$E[2X_{M+1}S_M | \mathcal{F}_M] \geq \frac{k_2 S_M^2}{M+1} + O\left(\frac{S_M}{M^2}\right), \quad (32)$$

$$E[X_{M+1}^2 | \mathcal{F}_M] \text{ is at least } \frac{\text{const.}}{M^2}. \quad (33)$$

See (12) and (14) of Pemantle (1990). His proof relies on the assumption that the noise term has a bounded support (and hence the step size is of order $\frac{1}{t+1}$). We will show that the same result holds in our setup where the noise is Gaussian.

Note that for any $v, \tilde{v} \in \mathbf{R}^n$ and sufficiently large M ,

$$\begin{aligned} & E \left[\eta \left(v + \frac{b(M, \tilde{v}) \varepsilon}{M+1} \right) \middle| \mathcal{F}_M \right] \\ &= E[\eta(v + zb(M, \tilde{v})\varepsilon)], \quad \text{where } z = \frac{1}{M+1} \\ &= \eta(v) + \frac{\partial E[\eta(v + zb(M, \tilde{v})\varepsilon)]}{\partial z} \bigg|_{z=0} z + O(z^2) \\ &= \eta(v) + \sum_{i=1}^n \frac{\partial \eta(v)}{\partial v_i} b_i(M, \tilde{v}) E[\varepsilon] z + O(z^2) \\ &= \eta(v) + O(z^2) = \eta(v) + O\left(\frac{1}{M^2}\right). \end{aligned}$$

To obtain the second equation, we regard the whole term as a function of z and apply Taylor expansion at $z = 0$. Intuitively, this shows that the impact of the noise ε in period M on the expected value of $\eta(v(M+1))$ is of order $O(\frac{1}{M^2})$. Then we have

$$\begin{aligned}
& E[S_{M+1} | \mathcal{F}_M] \\
&= E \left[\eta \left(v(M) + \frac{1}{M+1} (\tilde{F}(t, v(M)) + b(M, v(M))\varepsilon) \right) \middle| \mathcal{F}_M \right] \\
&= \eta \left(v(M) + \frac{\tilde{F}(t, v(M))}{M+1} \right) + O \left(\frac{1}{M^2} \right) = \eta \left(v(M) + \frac{F(v(M))}{M+1} \right) + O \left(\frac{1}{M^2} \right) \\
&\geq \frac{k_2 S_M}{M+1} + O \left(\frac{1}{M^2} \right),
\end{aligned}$$

which immediately implies (32). Here the third equation follows from the Lipschitz continuity of η , and $|F(v) - \tilde{F}(M, v)| < \frac{K}{M}$. The last inequality follows from Proposition 3(iv) of Pemantle (1990).

To obtain (33), note that

$$\begin{aligned}
E[X_{M+1}^2 | \mathcal{F}_M] &= (E[X_{M+1}^+ | \mathcal{F}_M])^2 \\
&\geq (\Pr(|\varepsilon(M)| < 1 | \mathcal{F}_M) E[X_{M+1}^+ | \mathcal{F}_M, |\varepsilon(M)| < 1])^2.
\end{aligned}$$

Conditional on $|\varepsilon(M)| < 1$, the step size $v(M+1) - v(M)$ is of order $\frac{1}{M+1}$. Hence as in the first display on page 709 of Pemantle (1990), we have

$$\begin{aligned}
& E[X_{M+1}^+ | \mathcal{F}_M, |\varepsilon(M)| < 1] \\
&\geq E \left[\left(D_{v(M)}(\eta) \left(\frac{\tilde{F}(M, v(M)) + b(M, v(M))\varepsilon}{M+1} \right) + O(|v(M+1) - v(M)|^2) \right)^+ \middle| \mathcal{F}_M, |\varepsilon(M)| < 1 \right] \\
&= E \left[\left(D_{v(M)}(\eta) \left(\frac{F(v(M)) + b(M, v(M))\varepsilon}{M+1} \right) + O \left(\frac{1}{M^2} \right) \right)^+ \middle| \mathcal{F}_M, |\varepsilon(M)| < 1 \right] \\
&\geq E \left[\left(D_{v(M)}(\eta) \left(\frac{b(M, v(M))\varepsilon}{M+1} \right) + O \left(\frac{1}{M^2} \right) \right)^+ \middle| \mathcal{F}_M, |\varepsilon(M)| < 1 \right] \\
&\geq \frac{\text{const.}}{M+1} + O \left(\frac{1}{M^2} \right).
\end{aligned}$$

Here the equality follows from linearity of $D_v(\eta)$, $|F(v) - \tilde{F}(M, v)| < \frac{K}{M}$, and the fact that the step size $v(M+1) - v(M)$ is of order $\frac{1}{M+1}$. The second to the last inequality follows from Proposition

3(v) of Pemantle (1990). The last inequality uses the fact that the gradient of η at p is $c'h$ for some $c' > 0$ and $h \in H^*$, which implies $D_v(\eta)(b(M, v(M))) \geq c'\kappa$ for any $v(M)$ in a neighborhood of p .

Substituting this inequality to the previous one, we obtain (33).

Step 2: Main Proof.

As argued in the full paragraph on page 709 of Pemantle (1990), combining (32) and (33) yields

$$E[2X_{M+1}S_M + X_{M+1}^2 | \mathcal{F}_M] \geq \frac{\text{const.}}{M^2},$$

which in turn implies

$$\begin{aligned} E[S_{\tau \wedge (M+1)}^2 | \mathcal{F}_t] - E[S_{\tau \wedge M}^2 | \mathcal{F}_t] &= E[1_{\tau > M}(2X_{M+1}S_M + X_{M+1}^2) | \mathcal{F}_t] \\ &= E[E[1_{\tau > M}(2X_{M+1}S_M + X_{M+1}^2) | \mathcal{F}_M] | \mathcal{F}_t] \\ &\geq \frac{\text{const.}}{M^2} E[1_{\tau > M} | \mathcal{F}_t] \\ &\geq \frac{\text{const.}}{M^2} \Pr(\tau = \infty | \mathcal{F}_t) \end{aligned}$$

for $M > t$. Pemantle (1990) applies this inequality iteratively and obtains

$$\begin{aligned} E[S_{\tau \wedge M}^2 | \mathcal{F}_t] &\geq S_t^2 + \text{const.} \cdot \Pr(\tau = \infty | \mathcal{F}_t) \sum_{i=t}^{M-1} \frac{1}{i^2} \\ &\geq \text{const.} \cdot \Pr(\tau = \infty | \mathcal{F}_t) \left(\frac{1}{t} - \frac{1}{M} \right). \end{aligned} \quad (34)$$

Then in the first paragraph on page 710, Pemantle (1990) shows that

$$\frac{4(c^*)^2}{t} \geq E(S_{M \wedge \tau}^2 | \mathcal{F}_t), \quad (35)$$

using the assumption that the noise has a bounded support (which ensures that the step size is of order $\frac{1}{M+1}$). We can show that the same result holds in our setup, the proof can be found at the end.

Then the rest of the proof is the same as Pemantle (1990): Combining (34) and (35),

$$\frac{4(c^*)^2}{t} \geq \text{const.} \cdot \Pr(\tau = \infty | \mathcal{F}_t) \left(\frac{1}{t} - \frac{1}{M} \right).$$

This inequality holds for all M , and when $M \rightarrow \infty$, it reduces to

$$4(c^*)^2 \geq \text{const.} \cdot \Pr(\tau = \infty | \mathcal{F}_t).$$

By taking c^* small enough, we have $\Pr(\tau = \infty | \mathcal{F}_t) \leq 0.5$, as desired.

Step 3: Proof of (35).

We will show that (35) holds in our setup: Let $L > 0$ be the Lipschitz constant of η , and $\hat{c} > 0$ be such that $|\tilde{F}(M, v) - v| < \hat{c}$ for all $M > t$ and for all v in a neighborhood of p . Then

$$\begin{aligned} |S_{M \wedge \tau} - S_{(M \wedge \tau) - 1}| &< L|v(M \wedge \tau) - v((M \wedge \tau) - 1)| \\ &\leq \frac{\hat{c}L + n\bar{b}|\varepsilon|L}{M \wedge \tau} \\ &\leq \frac{\hat{c}L + n\bar{b}|\varepsilon|L}{t}. \end{aligned} \tag{36}$$

whenever $v(M)$ is in the neighborhood of p . Since the mean of the half-normal distribution is $\frac{\sqrt{2}}{\sqrt{\pi}}$ and its variance is $1 - \frac{2}{\pi}$, we have

$$\begin{aligned} E[|S_{M \wedge \tau} - S_{(M \wedge \tau) - 1}| | \mathcal{F}_t] &< \frac{\text{const.}}{t}, \\ E[(S_{M \wedge \tau} - S_{(M \wedge \tau) - 1})^2 | \mathcal{F}_t] &< \frac{\text{const.}}{t^2}. \end{aligned}$$

Then we have

$$\begin{aligned} E[S_{M \wedge \tau}^2 | \mathcal{F}_t] &= E[\{S_{(M \wedge \tau) - 1} + (S_{M \wedge \tau} - S_{(M \wedge \tau) - 1})\}^2 | \mathcal{F}_t] \\ &\leq \left(\frac{c^*}{\sqrt{t}}\right)^2 + 2\frac{c^*}{\sqrt{t}}\frac{\text{const.}}{t} + \frac{\text{const.}}{t^2} \end{aligned}$$

where the inequality uses $S_{(M \wedge \tau) - 1} \leq \frac{c^*}{\sqrt{t}}$ (which follows from the definition of τ), the Lipschitz-continuity of η , and the previous inequalities. When t is large, the last line is less than $\frac{4(c^*)^2}{t}$, and hence (35) follows.

C.2.2 Proof of Lemma 7

The proof is almost the same as that of Pemantle (1990). However, at some places, his proof uses the assumption that the noise has a bounded support (which ensures that the step size of the process is of order $\frac{1}{t+1}$). In what follows, we will explain how to extend his argument to our setup with Gaussian noise.

Enlarge the domain of η as in the proof of Lemma 6. Pick t large enough, and assume that $S_t \geq \frac{c^*}{\sqrt{t}}$. Let $\tau = \inf\{k \geq t | S_k \leq \frac{c^*}{2\sqrt{t}}\}$. Recall that $X_k = S_k - S_{k-1}$ is a difference sequence. Let

$\mu_k = E[X_k | \mathcal{F}_{k-1}]$. Consider a martingale $\{Z_k\}_{k=t}^\infty$ defined as $Z_k = S_t + \sum_{j=t+1}^k Y_j$, where $Y_k = 0$ for $\tau > k$ and $Y_k = X_k - \mu_k$ for $\tau \leq k$.

In the seventh to the last line on page 710, Pemantle (1990) argues that if the step size is of order $\frac{1}{k}$, then $\{Z_k\}$ is L^2 -bounded (and hence the martingale convergence theorem applies).

In our setup, we can still prove that $\{Z_k\}$ is L^2 -bounded. It is well-known that a martingale $\{Z_k\}$ is L^2 -bounded if and only if

$$\sum_k E[(Z_k - Z_{k-1})^2] < \infty.$$

We will show that this inequality holds in our model. Using the argument similar to (36), we have

$$|S_k - S_{k-1}| < \frac{\hat{c}L + n\bar{b}|\varepsilon|L}{k}, \quad (37)$$

and hence

$$E[(S_k - S_{k-1})^2 | \mathcal{F}_{k-1}] < \frac{\text{const.}}{k^2}, \quad E[|S_k - S_{k-1}| | \mathcal{F}_{k-1}] < \frac{\text{const.}}{k}.$$

These inequalities imply

$$\begin{aligned} E[(Z_k - Z_{k-1})^2 | \mathcal{F}_{k-1}] &\leq E[(X_k - \mu_k)^2 | \mathcal{F}_{k-1}] \\ &= E[(S_k - S_{k-1})^2 - 2\mu_k(S_k - S_{k-1}) + \mu_k^2 | \mathcal{F}_{k-1}] \\ &= E[(S_k - S_{k-1})^2 - 2E[S_k - S_{k-1} | \mathcal{F}_{k-1}](S_k - S_{k-1}) + (E[S_k - S_{k-1} | \mathcal{F}_{k-1}])^2 | \mathcal{F}_{k-1}] \\ &< \frac{\text{const.}}{k^2}. \end{aligned}$$

Hence we have $E[(Z_k - Z_{k-1})^2] < \frac{\text{const.}}{k^2}$ for every k . Then obviously $\sum_k E[(Z_k - Z_{k-1})^2] < \infty$, as desired.

Also in the last line on page 710, Pemantle (1990) shows that if the step size is of order $\frac{1}{k}$, then

$$\text{Var} \left(\sum_{k=t+1}^{\tau} Y_k \right) \leq \sum_{k=t+1}^{\infty} \frac{\text{const.}}{k^2},$$

In our model, we can still prove the same inequality. It is well-known that the covariance of the martingale difference (Y_i, Y_j) is zero, and hence

$$\text{Var} \left(\sum_{k=t+1}^{\tau} Y_k \right) = \text{Var} \left(\sum_{k=t+1}^{\infty} Y_k \right) = \sum_{k=t+1}^{\infty} \text{Var}(Y_k).$$

Note that $E[(Z_k - Z_{k-1})^2] < \frac{\text{const.}}{k^2}$. Because $\text{Var}(Y_k) = E[(Z_k - Z_{k-1})^2]$, the desired inequality holds.